

OPERATOR'S MANUAL

model 90A backhoe

THIS MANUAL INCLUDES:

W435 BASIC BACKHOE

W462 - BUCKET, 12"

W463 - BUCKET, 18"

W464 - BUCKET, 24"

W460 - BUCKET, 36"

W461 - BUCKET, 40"

OPTIONAL STABILIZER ACCESSORIES

SERIAL NO. ²¹²⁸~~2048~~ AND LATER



THIS SAFETY ALERT SYMBOL
IDENTIFIES IMPORTANT SAFETY
MESSAGES IN THIS MANUAL



AMEREQUIP CORPORATION

1015 CALUMET AVENUE
KIEL, WISCONSIN 53042
414-894-7063

FORM W435 891
NO. 32051

PRINTED IN U.S.A.

CONTENTS

Safety Precautions.....	2 - 4
Basic Assembly Instructions.....	5 - 7
General Operation.....	7 - 12
Service.....	13, 14
Removal from Tractor and Storage.....	15
Optional Stabilizer Pads.....	16
Hydraulic Trouble Shooting.....	17 - 20
Valve Repair - Disassembly.....	21, 22
Control Valve.....	23 - 29
Backhoe - Valve Mount, Controls, and Seat.....	30
Backhoe - Mainframe, Swing Frame, and Stabilizers.....	31, 32
Backhoe - Boom, Dipperstick, and Bucket.....	33, 34
Torque Chart.....	34
Hose Diagrams.....	35, 36
Hydraulic Cylinders.....	37, 38
Specifications.....	39, 40
Purchase and Service Record.....	41

SAFETY PRECAUTIONS



ATTENTION! BECOME ALERT! YOUR SAFETY IS INVOLVED!

This symbol is used to call your attention to safety precautions that should be followed by the operator to avoid accidents. When you see this symbol - HEED ITS WARNING!

Failure to follow the safety messages and instructions shown in this manual may result in serious injury or death.

Many hours of lost time and much suffering is caused by the failure to practice simple safety rules.

IT IS TOO LATE TO REMEMBER WHAT SHOULD HAVE BEEN DONE AFTER THE ACCIDENT HAS HAPPENED.

BACKHOE SAFETY PRECAUTIONS:

Accidents can be avoided if the following safety rules are observed:

Preparation:

DO NOT operate the backhoe unless it is rigidly attached to the tractor.

KNOW YOUR controls. Read this operator's manual and the manual provided with your tractor. Learn how to stop the tractor, the engine, and the backhoe quickly in an emergency.

PROVIDE adequate front end weight to counter-balance the backhoe at all times. 20% of the total tractor, loader, and backhoe weight must be on the tractor front axle. If unsure of weight distribution, determine at a weigh scale.

BE SURE the area is clear of overhead or underground utilities or other hazards.

POSITION a barricade around the work area.

KEEP ALL bystanders a safe distance away.

Operation:

DO NOT attempt to enter operator's platform of backhoe by using stabilizers as a step.

OPERATE from the backhoe operator's seat only.

ALLOW only one person to operate the backhoe at any time.

DISENGAGE safety locks as shown in Fig 3, before attempting to operate the backhoe.

NEVER dig with the backhoe unless the stabilizers are properly set.

DO NOT dig under stabilizers or tractor-backhoe. Soft ground or sandy soil can cause cave-ins.

KEEP BUCKET away from stabilizer area to avoid possible stabilizer damage.

ALWAYS swing bucket uphill to dump when on a hillside and keep loaded bucket low.

SET BRAKES and block wheels when operating on hills and banks to avoid dangerous run-away.

WATCH for overhead wires. DO NOT touch wires with any part of the backhoe.

NEVER allow a person to work under a raised bucket.

NEVER lift a person with the backhoe.

DO NOT use the backhoe bucket as a battering ram. Use the backhoe only for digging.

ALWAYS lower the backhoe bucket and stabilizers to the ground, shut off engine, and apply the parking brake before getting off unit, or when not digging.

NEVER leave the tractor unattended with the engine running.

DO NOT attempt to raise the tractor off the ground or move the tractor forward or backward using the backhoe dipperstick or bucket.

Transportation:

ALWAYS engage safety locks before transporting backhoe. See Fig 3, page 7.

DO NOT drive the tractor near the edge of a ditch or excavation.

ALWAYS use accessory lights and devices, when transporting on a road or highway, to warn operators of other vehicles. Check your local government regulations.

BE SURE that the SMV emblem is visible to the rear.

Adjustments and Inspection:

CHECK pins that attach backhoe to tractor and all pivot pins for tightness several times daily. Replace any parts which are bent, broken, or missing.

ALWAYS engage safety locks before servicing backhoe. See Fig 3, page 7.

DO NOT oil, grease, or adjust the backhoe while it is in motion. For greasing see Service section for details.

DO NOT change any backhoe relief valve settings. They are factory set for best backhoe performance and safety.

PROTECT YOUR EYES - WEAR SAFETY GLASSES.

GUARD AGAINST INJURY when driving connecting pins or performing any repair in which particles can chip from work piece or striking tool.

DO NOT REMOVE ANY GUARDS on backhoe or tractor.

AVOID HIGH-PRESSURE FLUIDS



ESCAPING FLUID under pressure can have sufficient force to penetrate the skin and cause serious injury. Be sure to stop engine and relieve all pressure before disconnecting lines. Be sure all connections are tight and that lines, pipes, and hoses are not damaged before applying pressure to the system.

FLUID ESCAPING from a very small hole can be almost invisible. Use a piece of cardboard or wood - not your hands - to search for suspected leaks.

SEE A DOCTOR AT ONCE if injured by escaping fluid. Serious infection or gangrene can develop if proper medical treatment is not administered immediately.

SAFETY DECALS

! The safety of the operator was a prime consideration in the design of this backhoe. Proper shielding, convenient controls, simple adjustments, and other safety features have been built into this backhoe.

The following decals are located on the backhoe. Keep decals clean, and replace them immediately if they are missing, damaged, or no longer readable. Contact your Dealer or Amerequip for replacements.



DANGER

CRUSHING HAZARD

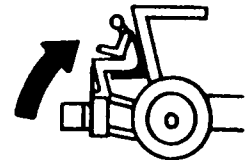

DO NOT OPERATE 3-POINT RIGID MOUNT BACKHOE UNLESS HITCH AND STABILIZER BARS ARE INSTALLED PROPERLY. FAILURE TO DO SO MAY RESULT IN SERIOUS INJURY OR DEATH FROM BACKHOE BEING THRUST UPWARD BY DIGGING FORCES - CRUSHING OPERATOR.

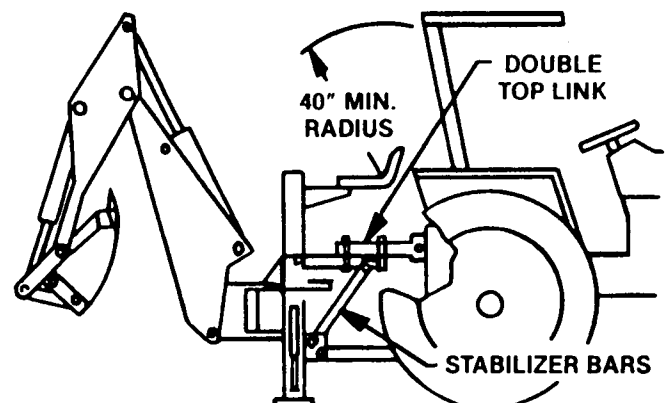

USE ONLY SPECIAL HITCH PARTS SUPPLIED WITH BACKHOE. SEE OPERATOR'S MANUAL FOR PROPER ASSEMBLY AND ADJUSTMENT OF HITCH.

10075

Part Number: 10075

Location: Left Side of Valve Shroud

IMPORTANT

IMPROPER HYDRAULIC HOOK-UP CAN CAUSE SERIOUS DAMAGE TO VALVE

- REFER TO ATTACHING KIT OR PTO PUMP KIT MANUAL FOR PROPER HYDRAULIC HOOK-UP.
- NEVER PRESSURIZE RETURN PORT OF VALVE OR RESTRICT RETURN HOSE.
- ALWAYS MOVE TRACTOR 3-POINT HITCH CONTROL TO FULLY LOWERED POSITION WHILE BACKHOE IS MOUNTED TO TRACTOR.

Part Number: 10052

Location: Left Side of Valve Mount Plate



CAUTION

1. READ OPERATOR'S MANUAL BEFORE USING BACKHOE.
2. OPERATE BACKHOE CONTROLS ONLY FROM NORMAL BACKHOE OPERATOR'S SEAT POSITION.
3. OPERATE ONLY WITH STABILIZERS DOWN AND ON FIRM FOOTING. AVOID DIGGING IN AREA OF STABILIZER PADS. STAY CLEAR OF STEEP AREAS OR EXCAVATION BANKS THAT COULD GIVE WAY.
4. CHECK THE OPERATING AREA TO BE DUG FOR ANY POSSIBLE OVERHEAD OR UNDERGROUND LINES SUCH AS ELECTRIC, GAS, OIL, WATER, ETC., AND EXTREME CAUTION MUST BE EXERCISED IN THESE AREAS WHERE PRESENT. CONSULT LOCAL UTILITIES BEFORE DIGGING.
5. KEEP BYSTANDERS AWAY FROM MAXIMUM SWING REACH AREA AND STABILIZERS.

10088

Part Number: 10088

Location: Left Side of Control Shroud



WARNING

TO PREVENT BODILY INJURY: DO NOT OPERATE THIS BACKHOE UNLESS IT IS RIGIDLY ATTACHED TO THE TRACTOR USING THE APPROPRIATE FACTORY-PROVIDED MOUNTING KIT. DO NOT MOUNT BACKHOE ON A 3-POINT "QUICK ATTACHING COUPLER!"

10076

Part Number: 10076

Location: Top of Seat Bracket



CAUTION

6. KEEP ALL GUARDS IN PLACE.
7. INSPECT BACKHOE DAILY FOR LOOSENED, BENT, OR BROKEN PARTS.
8. ENGAGE SAFETY LOCKS BEFORE TRANSPORTING OR SERVICING BACKHOE.
9. BE SURE TRACTOR IS WEIGHTED TO PROVIDE AT LEAST 20% OF TOTAL WEIGHT ON FRONT WHEELS WITH BACKHOE IN TRANSPORT POSITION.
10. DO NOT USE WITH TRACTOR HYDRAULIC SYSTEMS THAT EXCEED 12 GPM FLOW RATE OR 2500 PSI OPERATING PRESSURE.
11. FOR 3-POINT RIGID MOUNT BACKHOES ONLY: MOUNT ONLY TO TRACTORS FROM 35 TO 90 PTO HP WITH CAT I OR II HITCH. 1450 LB. LIFT FORCE REQUIRED AT 24 IN BEHIND LIFT POINT.

10090

Part Number: 10090

Location Right Side of Control Shroud

AVOID ACCIDENTS

BUILT-IN SAFETY FEATURES CAN BE EFFECTIVE ONLY IF PROPERLY MAINTAINED AND UTILIZED

BASIC ASSEMBLY INSTRUCTIONS

General:

The backhoe has been partially disassembled and strapped to a skid for shipping purposes. Initial installation on the tractor will require a hoist or other device capable of safely lifting the entire backhoe from the skid. Once the initial installation is complete the backhoe can serve as its own erecting hoist, by lowering stabilizers and bucket to the ground, and additional lifting devices will not be required for normal removal and reattaching.

Assembly Procedure - Fig 1 and 3:

IMPORTANT - Tighten all hardware to torque requirements specified in Torque Chart, Page 34, of this manual.

1. Remove the stabilizer assemblies and any miscellaneous items which have been fastened to the skid and arrange conveniently. Remove corrugated packaging from dipperstick.

! *CAUTION* - DO NOT cut any strapping that fastens the backhoe mainframe and swing frame to the skid base at this time.

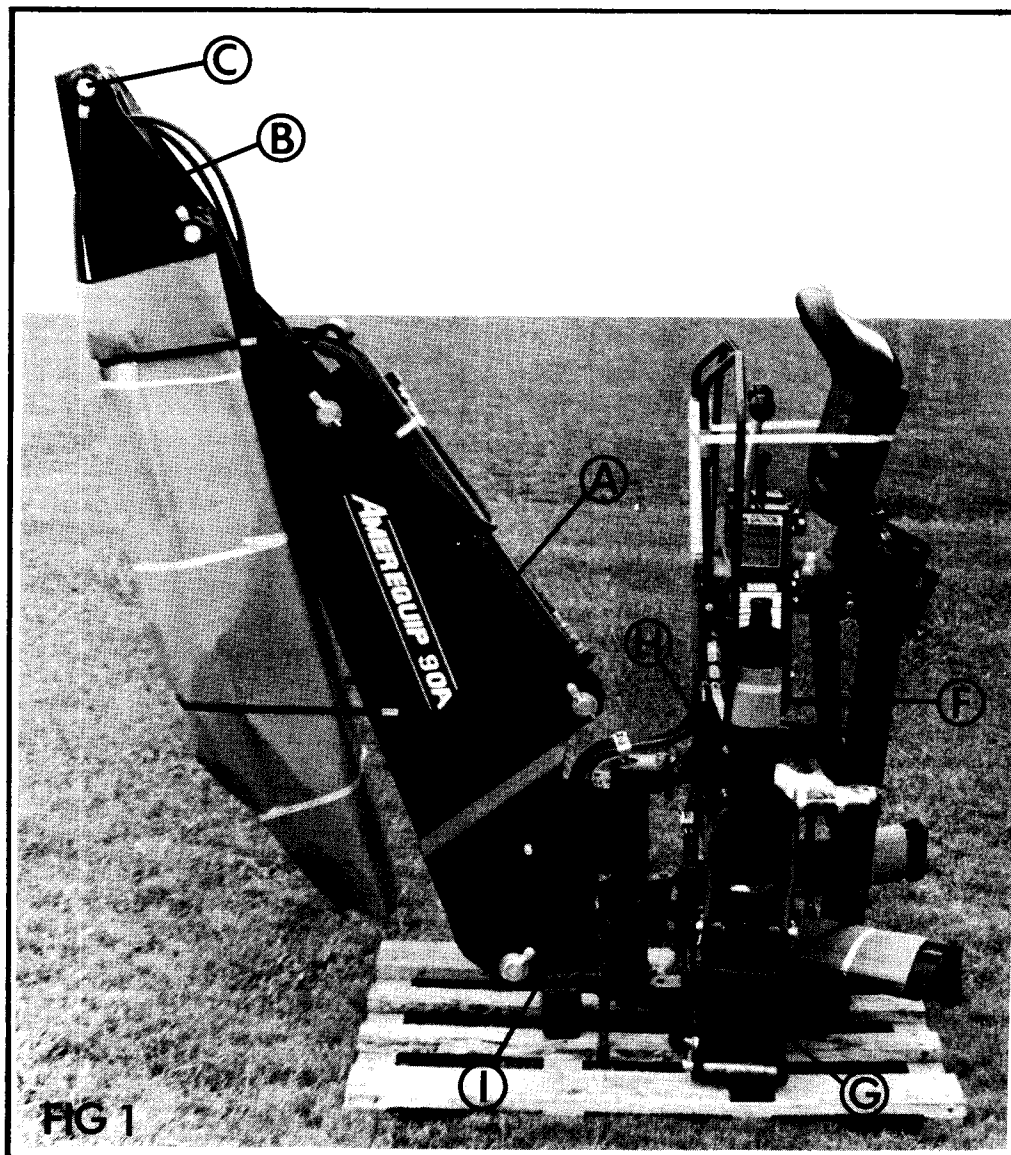

Basic Assembly - continued

2. Support boom (A) and dipperstick (B) with hoist and remove boom transport lock pin. Store lock pin in top of valve cover when not in use. Lower boom and manually extend dipperstick until dipperstick rests on ground and dipperstick cylinder can be attached at point (C) with hardware provided. Move control handle to "BOOM DOWN" position as required to aid movement. Note that the hydraulic hoses are routed under the cylinder rod bushing.

⚠ CAUTION - Be sure hoist being used is suitable, has sufficient capacity, and is in the proper position. Do not allow anyone under a backhoe member that is supported by the hoist.

3. Remove plastic bag containing bucket pins from footpad. Attach bucket (D) to dipperstick using one pin, two bolts, nuts, lockwashers, pin retainers, and washers as necessary.

4. Attach bucket link (E) to bucket using same hardware as listed for step #3.

5. Attach hoist to backhoe to prevent tipping. Remove all remaining strapping and attach stabilizers (F) to mainframe (G) using pins and hardware assembled to mainframe.

6. Attach stabilizer cylinders (H) to stabilizers using pins and hardware assembled to stabilizers.

7. Using caution to prevent tipping, raise mainframe with hoist to a height of approximately 11 inches, and remove skid. Block mainframe (G) and swing frame (I) securely.

8. Follow the Attaching Kit Assembly Instructions to mount the backhoe to the tractor. Check the installation carefully making sure that all members are correctly installed and securely fastened.

9. Assemble 1-9/16 ID x 18" hose sleeve on hose which attaches to backhoe valve "in" port. Position hose sleeve to cover adapter union and secure with plastic tie.

⚠ CAUTION - Hose sleeve is installed to help protect the backhoe operator from escaping fluid under pressure. If it becomes damaged or lost, replace hose sleeve and plastic tie immediately, see Fig 17.

10. Continue with the "GENERAL OPERATION" Section to familiarize yourself with the backhoe controls and with safe operating practices.

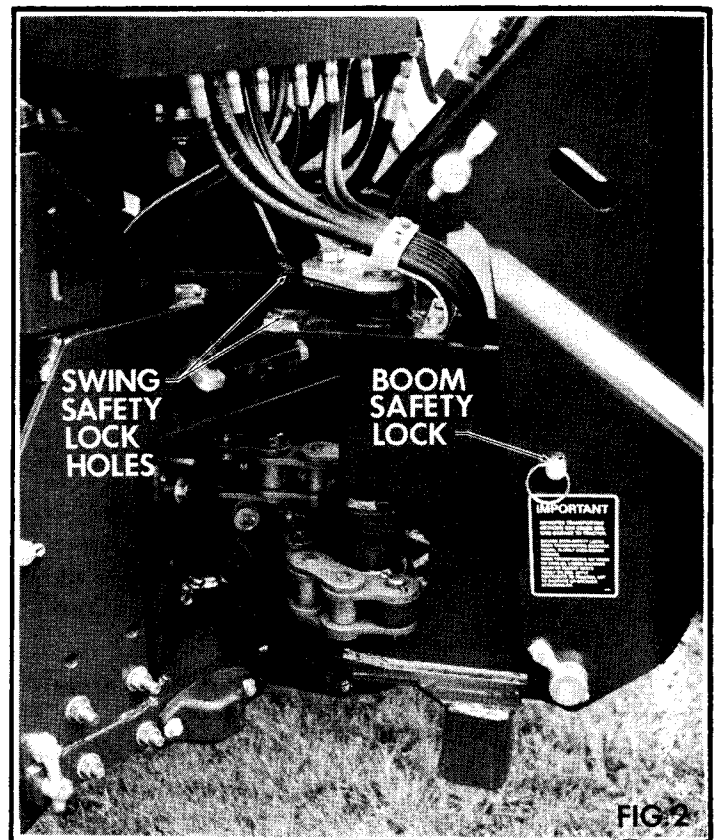

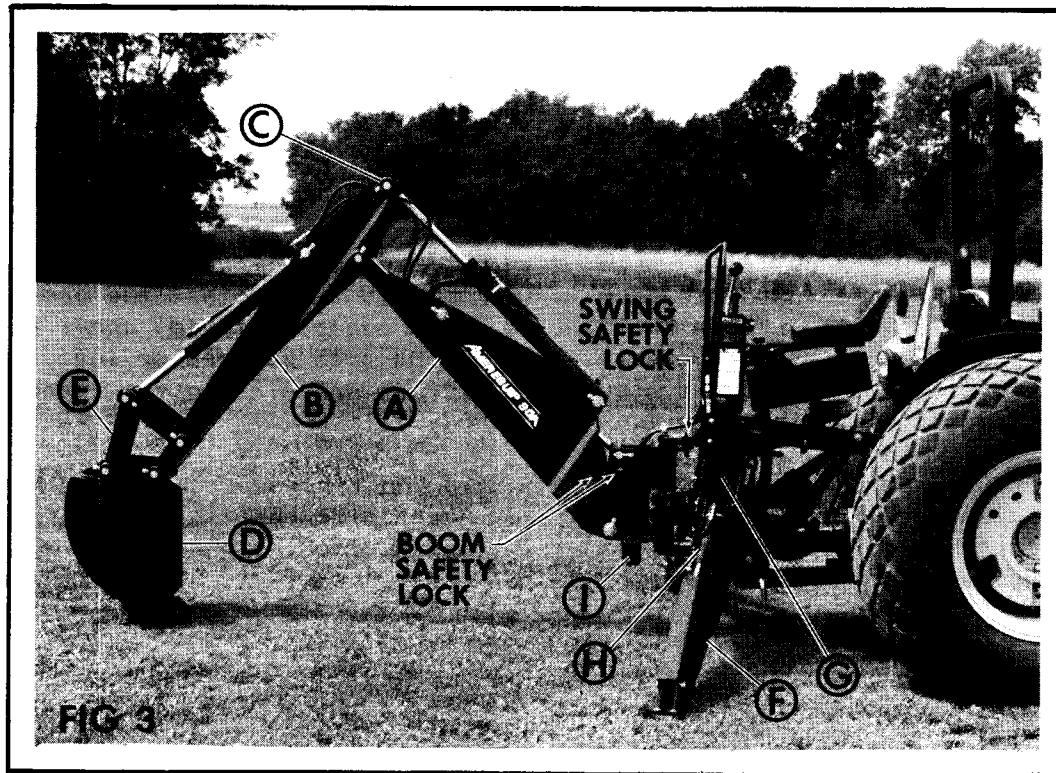

GENERAL OPERATION



CAUTION - To avoid possible injury, observe the following safety rules BEFORE OPERATING the backhoe:

1. BE SURE area is clear of underground utilities or other hazards.
2. POSITION a barricade around work area.
3. PROVIDE adequate front end weight to counter-balance backhoe at all times. 20% of the total tractor, loader, backhoe weight must be on the tractor front axle.
4. KEEP bystanders a safe distance away.

Directions:

The terms right, left, front, and back shall be determined from the position of the operator when seated in the operating position on the backhoe.

Engine Speed:

The speed at which the backhoe operates is partially dependent on engine RPM. Use a moderate engine speed to start and increase it as your experience permits. Refer to "SPECIFICATIONS" for hydraulic flow volume requirements. When powering from tractor systems with higher output,

reduce engine RPM to obtain acceptable backhoe operating speed.

Controls:

The backhoe has two major control levers plus the stabilizer control levers. These controls are located on the control panel directly ahead of the operator, see Fig 4. Following is a list of the controls, with the function of each, reading from left to right.

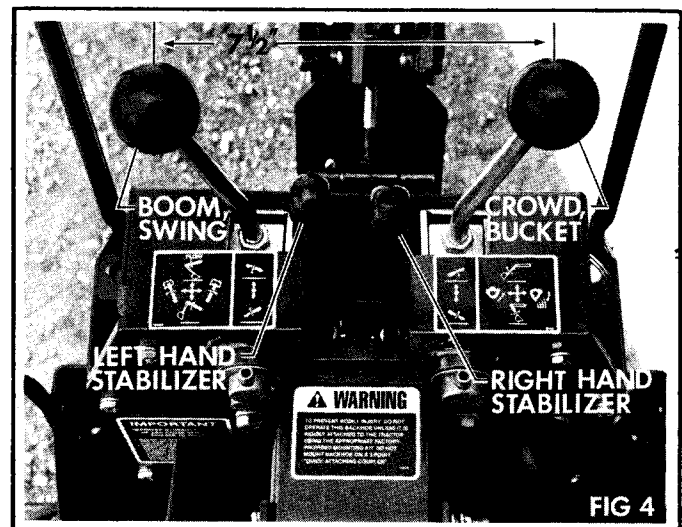

General Operations - continued

1. Boom/Swing:

Push lever forward, the boom moves down, away from the operator. Pull lever back, the boom moves up, toward the operator.

The Boom/Swing Control Lever has an added "float" function. A detent or stop should be felt when the lever is pushed forward to move the boom down. Pushing the lever forward more will overcome the detent and cause the boom to float or move down or up freely depending on the forces acting on it. When the lever is released it should return to the center, neutral position.

Move lever to left, the backhoe swings to the left. Move lever to right, the backhoe swings to the right.

By moving the lever to one of the intermediate positions, the boom can be swung left or right at the same time it is being raised or lowered, performing the two operations simultaneously.

SWING LEFT AND LOWER the boom by moving the control lever forward and to the left.

SWING LEFT AND RAISE the boom by moving the control lever back and to the left.

SWING RIGHT AND LOWER the boom by moving the lever forward and to the right.

SWING RIGHT AND RAISE the boom by moving the lever back and to the right.

2. Left Hand Stabilizer:

Push lever forward, the LH stabilizer lowers. Pull lever back, the LH stabilizer raises.

3. Right Hand Stabilizer:

Push lever forward, the RH stabilizer lowers. Pull lever back, the RH stabilizer raises.

4. Crowd/Bucket:

Push lever forward, the dipperstick moves out, away from the operator. Pull lever back, the dipperstick moves in, toward the operator.

Move lever to left, the bucket curls in. Move lever to right, the bucket extends out.

By moving the lever to one of the intermediate positions, the dipperstick can be extended or retracted at the same time the bucket is being loaded or dumped.

EXTEND AND LOAD the bucket by moving the lever forward and to the left.

RETRACT AND LOAD the bucket by moving the lever back and to the left.

EXTEND AND DUMP the bucket by moving the lever forward and to the right.

RETRACT AND DUMP the bucket by moving the lever back and to the right.

The two operations of the boom lever, combined with the two operations performed by the bucket and dipperstick control lever provide four simultaneous operations from the two levers, keeping cycle time at a minimum.

In general, the direction of movement of a control lever corresponds to the movement of the operating member.

Operating The Backhoe:



CAUTION - To avoid possible injury, observe the following safety rules WHEN OPERATING the backhoe:

1. DISENGAGE safety locks as shown in Fig 2 or 3, before attempting to operate the backhoe. Store lockpins in holes provided in top of valve shroud.
2. OPERATE from the backhoe operator's seat only.
3. LOWER the stabilizers until the rear of the tractor is totally supported by them. NOTE: rear tires should not come up off of the ground, see diagram on page 10.
4. DO NOT dig near the stabilizers.
5. DO NOT touch overhead wires with any part of the backhoe.
6. DO NOT attempt to raise the tractor off the ground or move the tractor forward or backward using the backhoe dipperstick or bucket.
7. DO NOT lose stability by swinging the bucket downhill when positioned on a slope.

General Operations - continued

8. DO NOT lower the backhoe boom using the "float" function. It will free-fall, and could result in injury to bystanders or damage to the backhoe.

It is not difficult to become an efficient operator. Control lever operating decals are located in front of the control levers. Study these decals; they will assist you in becoming familiar with the controls.

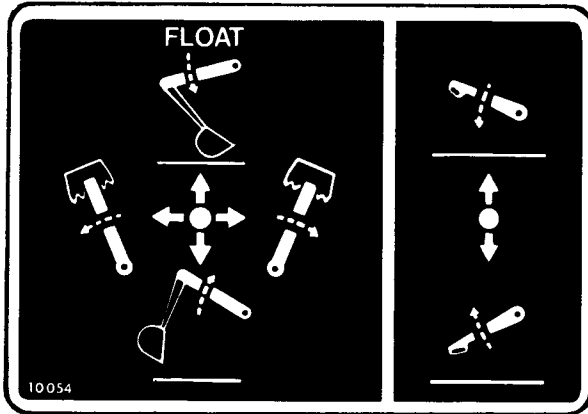

Part Number: 10054
Location: Top of Control Shroud, left side

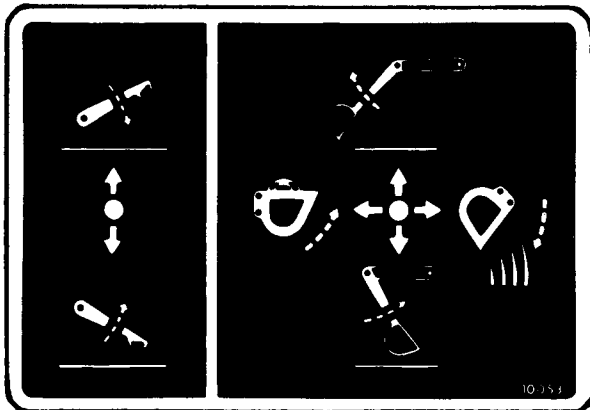

Part Number: 10053
Location: Top of Control Shroud, right side

Smooth, light handling of the controls will result in the most efficient backhoe operation.

Operate the backhoe control levers to become familiar with their speed and movements. The engine speed and the size of the hydraulic system will determine the speed of cylinder operation. When powering from tractor systems with higher output than required, reduce engine RPM to obtain acceptable backhoe operating speed.

Swing the boom several times to practice controlling the speed of swing. Do not operate the swing more than 45 degrees each way for the first few times, then gradually increase the arc.

IMPORTANT - To avoid damage to the backhoe, do not slam swing unit into the rubber bumper pads.

The boom "float" function may be used during digging to eliminate down pressure when cleaning the bottom of a trench. The primary purpose of the boom "float" function is to protect the operator from serious injury in the event that the backhoe or tractor hitch would fail.

Best results are obtained by digging near the center of the swing arc so material can be dumped on either side.

As the operator becomes more familiar with the operation of the backhoe, it will be common practice to operate two controls at one time. For example; with the bucket extended and the dipperstick extended, the lift control and crowd control can be operated together to bring the bucket toward the operator with down pressure on it. As the dipperstick approaches the operator, the crowd and bucket controls can be operated to close the bucket and trap the material. At the end of the stroke, the lift and crowd controls are operated to move the load up and away from the operator to save time in clearing the excavation.

This dual operation of controls will speed and simplify the digging operation. Normally the two or more movements will not be equal or even simultaneous but as pressure within the cylinders change, and the resistance on an operating member of the hoe lessens, it will begin to move. It is balancing the force of one member against the other.

NOTE - Actuating the bucket is the key to powerful digging. Operating the crowd and bucket controls simultaneously will insure a full bucket and prevent waste motion and time.

Transporting The Backhoe:

⚠ CAUTION - To avoid possible injury, observe the following safety rules WHEN TRANSPORTING the backhoe:

1. ALWAYS engage safety locks as shown in Fig 3, when transporting backhoe.
2. TRAVEL SLOWLY over rough terrain, on hillsides, and around curves to prevent tipping.
3. DO NOT drive the tractor near the edge of a ditch or excavation.
4. USE accessory lights and SMV emblem when traveling on highways.

Before leaving backhoe operator's seat, position the backhoe for transport by raising boom, crowding dipperstick in, curling bucket in, swinging to center, and raising the stabilizers.

When transporting for long distances, periodically examine the backhoe and raise stabilizers and bucket back up to full transport height. It is normal for the hoe to slowly settle while being transported.

IMPORTANT - To prevent serious damage to the tractor, read and follow the instructions on the following decal:

IMPORTANT

IMPROPER TRANSPORTING METHODS CAN CAUSE SERIOUS DAMAGE TO TRACTOR.

- ENGAGE BOTH SAFETY LOCKS WHEN TRANSPORTING BACKHOE.
- TRAVEL SLOWLY OVER ROUGH TERRAIN.
- WHEN TRANSPORTING ON TRUCK OR TRAILER, LOWER BACKHOE BOOM SO BUCKET RESTS FIRMLY ON BED. APPLY RESTRAINTS TO TRACTOR, NOT TO BACKHOE OR BACKHOE ATTACHING KIT.

10099

Part Number: 10099
Location: Right Side of Boom

PLACING THE STABILIZERS:

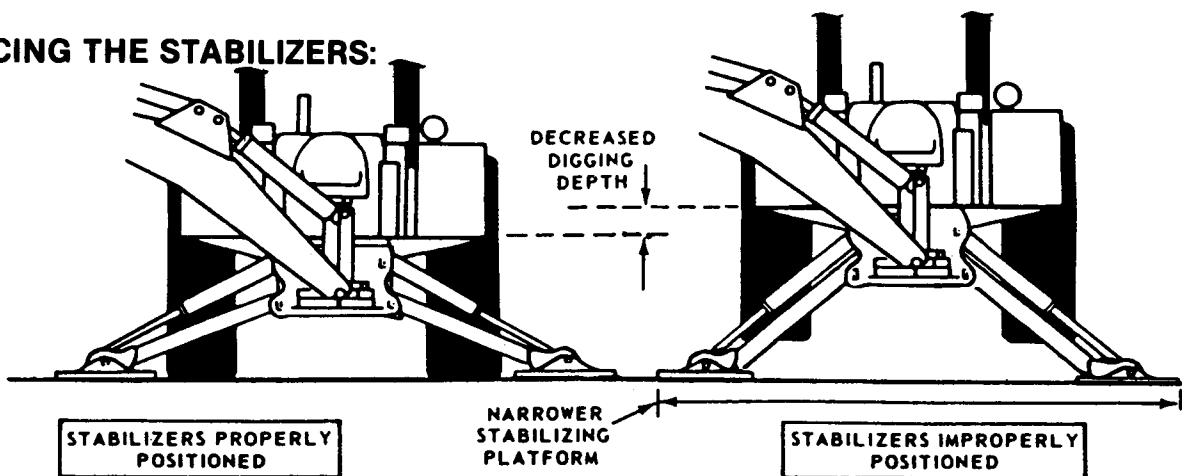

Set the stabilizers to remove weight from the rear wheels. The wheels are to remain touching the ground as this provides for the widest stabilizer stance and the lowest center of gravity. Raising the wheels off the ground will not only reduce stability and digging depth, but will impair performance and impose unnecessary stress on the unit.

General Operations - continued

FILLING THE BUCKET

Control the bucket attitude throughout the digging cycle to keep teeth at the proper angle for best penetration. This will minimize dragging and scraping the bucket through the ground.

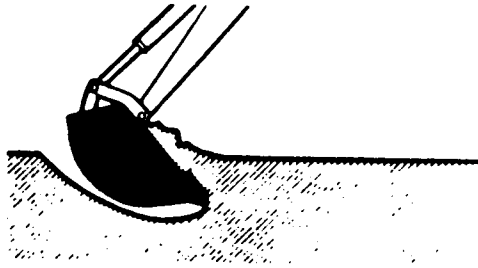

When digging in hard-packed soil, bucket penetration can be increased by applying down pressure with the boom while crowding in and curling the bucket. If the crowd action "stalls," it may be necessary to apply lift occasionally during the digging cycle to correct the bucket depth.

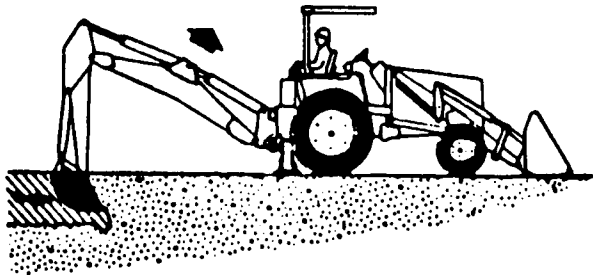

To obtain a cleaner trench and avoid the buildup of material directly in front of the backhoe, crowd out and completely curl the bucket while starting to lift it from the excavation. In this way, excess material will fall back into the excavation.

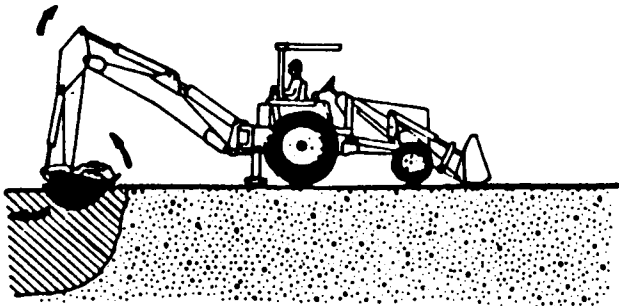

DUMPING THE BUCKET

To dump the bucket at the end of the digging cycle, lift the bucket clear of the trench while crowding it out and swinging it to the spoil pile.

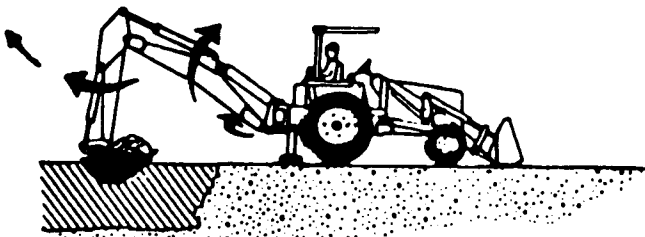

As the pile is approached, dump the bucket. When the bucket is empty, the dipstick and bucket are in position to resume digging upon return to the trench.

IMPORTANT — Avoid constant jarring or hammering-type contact between the spoil pile and the loaded bucket as this may cause premature wear to the backhoe pins and bushings.

TRENCHING BETWEEN A BUILDING & OPEN EXCAVATIONS

Start the trench at the building. Trench out halfway to the excavation. Then, start trenching from the excavation to the first trench. Dig toward the first trench until there is just enough room to move the unit out from between the two trenches.

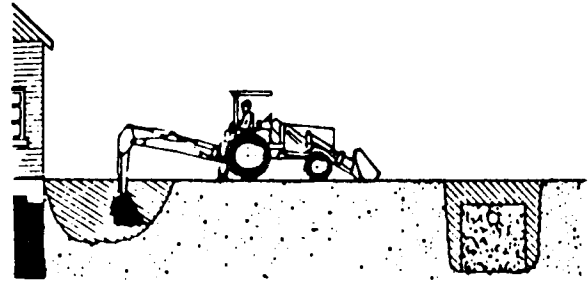

Position the unit so the backhoe swing post is over the centerline of the trench connection. Dig with the backhoe at extreme swing positions, and in as close to the stabilizers as possible. Pile the spoil on the opposite side of the trenches.

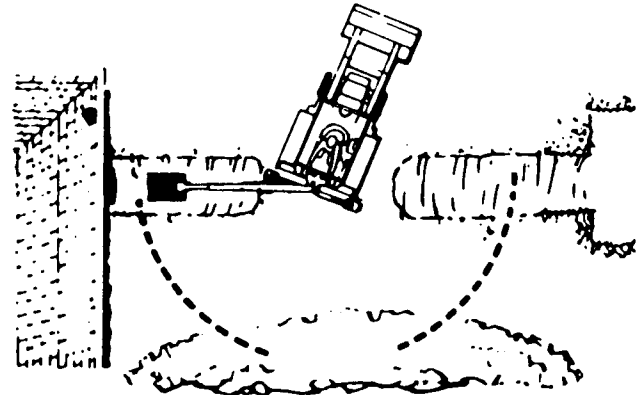

Position the unit forward with the lift and crowd levers so the two trenches can be connected. Pile the spoil on the opposite side of the trench.

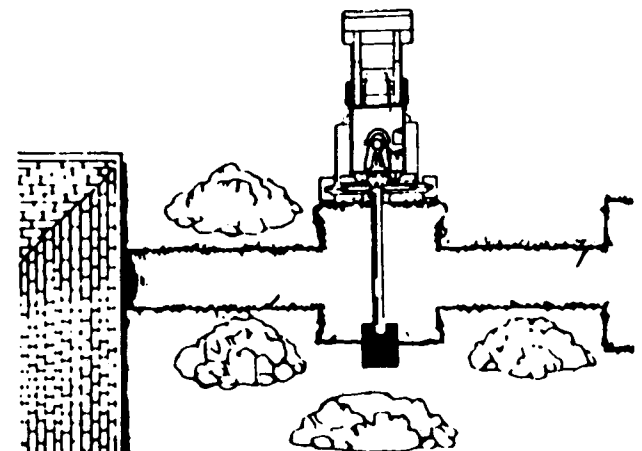

General Operations - continued

SIDE SLOPE EXCAVATING OR TRENCHING

Dig with the backhoe uphill whenever possible.

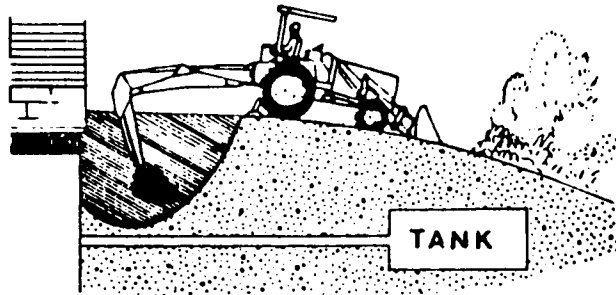

Level the backhoe on slopes with the stabilizers to dig plumb trenches, or use the backhoe or loader to cut a level slot for the uphill wheel and stabilizer. Pile the spoil from the slot on the low side.

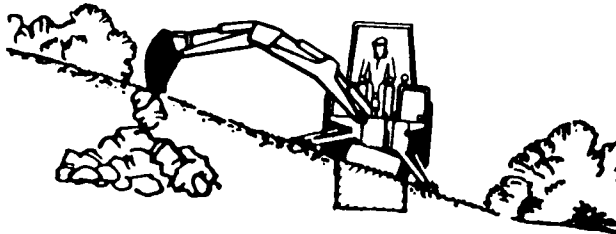

When on the side of a steep slope, cut a level surface along the uphill side of the trench with the loader.

Pile the spoil of the cut downhill. When digging, pile the spoil of the trench uphill.

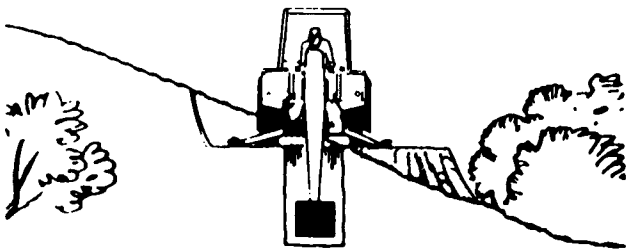

Dig field trenches progressively. As soon as one trench is completed, have the workmen lay the tile. Start the next trench, using the spoil to fill the previous trench.



MISCELLANEOUS

When finishing straight walls or bellholes in sandy soil, use a platform under the rear tires and the stabilizers. The platform distributes the load over a larger area and lessens the possibility of a cave-in. The platform also tends to keep the unit from creeping rearward if hard digging is encountered.

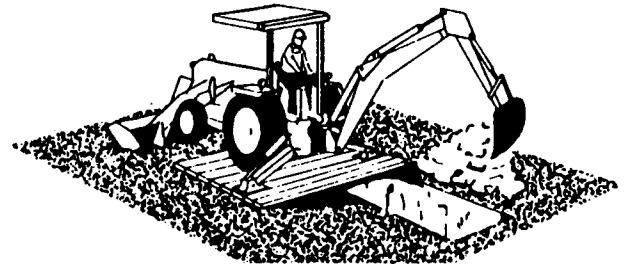

FINISHING STRAIGHT WALLS

Finish the far wall by crowding out while forcing the bucket down with the boom. Actuate the bucket (curl out) to keep the bottom of the bucket vertical.

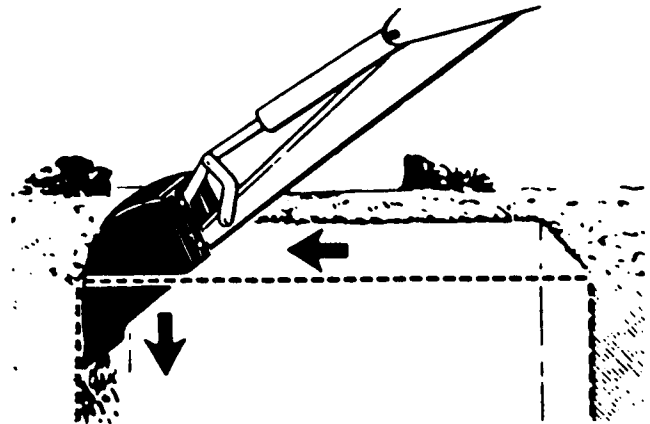

To finish the rear wall, lift up and crowd in. Keep the edges of the bucket horizontal.

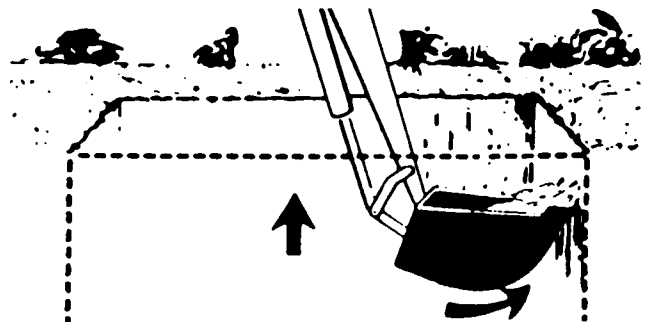

BACKFILLING

Backfill by lifting the bucket over the spoil pile and then crowding in. Pull both the crowd and lift levers for smooth, even backfilling.

IMPORTANT — Do not backfill by using the swing circuit and dragging the bucket sideways. Doing so can cause damage to the dipstick, boom, swing cylinders or mainframe.

SERVICE

⚠ CAUTION - To avoid possible injury, observe the following safety rules WHEN SERVICING the backhoe:

1. ENGAGE safety locks as shown in Fig 3, before servicing the backhoe.
2. DO NOT oil, grease, or adjust the backhoe while it is in motion.
3. DO NOT change any backhoe relief valve settings. They are factory set for best backhoe performance and safety.

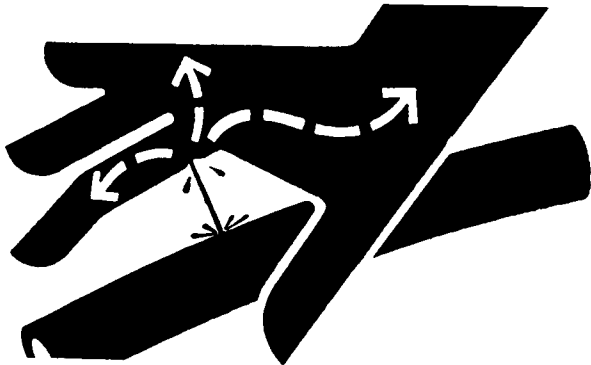

4. ESCAPING FLUID under pressure can have sufficient force to penetrate the skin and cause serious injury. Be sure to relieve all pressure before disconnecting lines. Be sure all connections are tight and that lines, pipes, and hoses are not damaged before applying pressure to the system.
5. FLUID ESCAPING from a very small hole can be almost invisible. Use a piece of cardboard or wood - not your hands - to search for suspected leaks.
6. SEE A DOCTOR AT ONCE if injured by escaping fluid. Serious infection or gangrene can develop if proper medical treatment is not administered immediately.
7. PROTECT YOUR EYES - WEAR SAFETY GLASSES. Guard against injury when driving connecting pins or performing any repair in which particles can chip from work piece or striking tool.

Beginning Of Season:

Remove all protective covering.

Check hydraulic hoses for deterioration and, if necessary, replace.

Lubricate all grease fittings and oil handle linkage.

Check hydraulic system for loss of fluid and, if necessary, fill to proper level.

Tighten all loose bolts, nuts, and set-screws.

Inspect bucket teeth and, if necessary, sharpen or replace them.

Operate the backhoe slowly for a short time before placing the unit under full load.

Bleeding Backhoe Hydraulic System:

If the hydraulic hoses have been disconnected from the backhoe or tractor, all trapped air must be removed after the hoses are connected. Start tractor engine and operate backhoe through all movements fully, several times, to purge the system of air.

Hydraulic System Hoses:

Oil leaks in the pressure side of the system can be located by carefully inspecting the external area of the hoses and fittings.

Check the return side of the system for leaks by examining the oil in the reservoir. If air is being drawn into the system, the oil will contain air bubbles and appear to foam.

When tightening connections, always use two wrenches.

IMPORTANT - Do not over-tighten fittings. Make them just tight enough to eliminate leaks.

NEVER use teflon tape on pipe thread fittings. Always use a paste type sealer.

Hoses on any backhoe are very severely worked and will fail in time. Examine them regularly and replace any that show signs of failure. Pay careful attention to the routing of hoses so they can move fully and freely, without kinking, and can not be pinched or cut by any part of the backhoe.

Hydraulic System Reservoir:

On PTO pump self-contained systems, maintain the reservoir fluid level at 1 inch below the tank top when the bucket is extended to full reach, bucket rolled back for loading and resting on the ground, and stabilizers fully raised. Do not over-fill, fluid may be forced out of the breather filler cap.

Service - continued

Fill with:

SAE 10W40 engine oil with API "SD" classification in northern climates.

SAE 40W engine oil with API "SD" classification in southern climates.

Change oil every 200 hours or more often if necessary.

If the tractor system supplies the hydraulic power, service according to the tractor instruction manual.

Bucket Tooth Points:

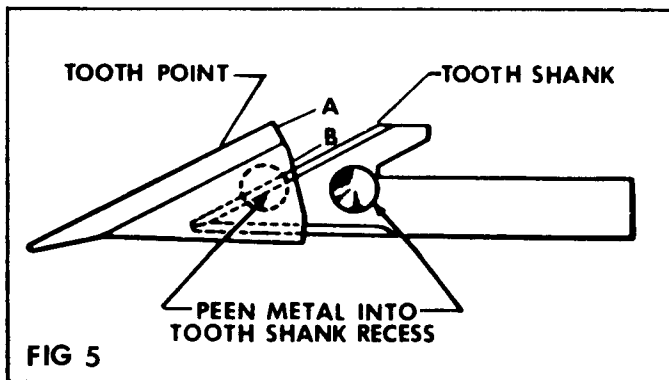

The bucket tooth points are self-sharpening and will require little attention; however, these points on the bucket shanks can be replaced when they become badly worn or broken.

A tooth point can be removed from the welded tooth shank by hammering at "A" on the tooth point or by driving a chisel at "B", just between the tooth point box section and the tooth shank. Install the new point and anchor it to the shank by peening at the location shown.

If a tooth shank breaks off, becoming lost or damaged so that it can not hold a tooth point, a new shank should be welded to the bucket in its place.

Tightening Nuts And Bolts:

Periodically, check to be sure all bolts and nuts are tight, see Torque Chart, page 34.

Check all pivot pins for cotter pins, washers, and retainers; if missing - replace.

LUBRICATION:

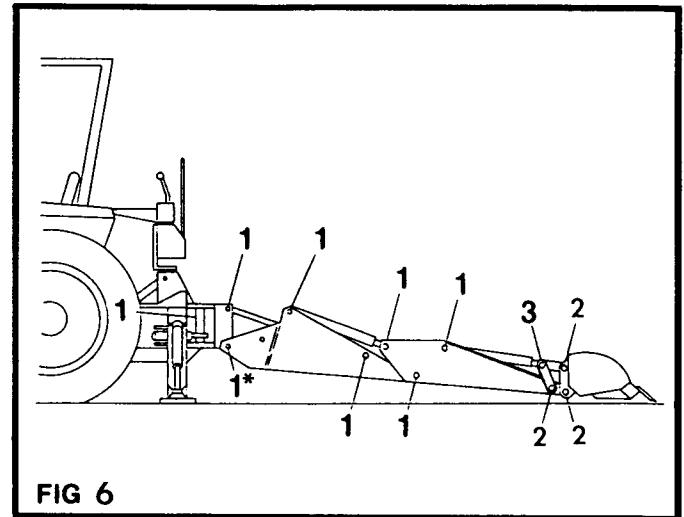

Economical and efficient operation of any machine is dependent upon regular and proper lubrication of all moving parts with a quality lubricant.

All parts provided with grease fittings should be lubricated with a good quality chassis lube type grease. If any grease fittings are missing, replace them immediately. Clean all fittings thoroughly before using grease gun.

Lubricate all grease fittings at least twice daily, once at the beginning of operation and again approximately half-way through the work day.

Lower stabilizers to the ground, extend dipperstick and bucket, and lower boom so bucket rests on ground, as shown in Fig 6, before greasing.

IMPORTANT - Before greasing boom to swing frame pivot () shown in Fig 6, raise boom and install transport lock pin as shown in Fig 3.*

See Fig 6 for the location of all grease fittings. In addition, the following locations should be oiled with SAE 30 oil:

- A. Swing Chains
- B. Stabilizer Pivot Pins
- C. Control handle Linkage
- D. Seat Bracket Pivot

IMPORTANT - Avoid excessive greasing. Dirt collects on exposed grease and increases wear greatly. After greasing wipe off excessive grease from fittings.

REMOVAL FROM TRACTOR-STORAGE

The backhoe is self-assisting during the installation and removal procedures. For removal and storage follow these steps:

1. Install the swing safety lock pin as shown in Fig 3, and raise the backhoe operator's seat until it locks in the raised position.
2. Put the stabilizers down and lift the hoe slightly.
3. Stretch out the boom, dipper arm, and bucket, as shown in Fig 7. Lower the bucket to the ground so that it rests there solidly.
4. Place suitable blocking under the backhoe frame to support it adequately, as shown in Fig 7.
5. Detach the backhoe from the tractor mechanically only, not hydraulically at this point, and move the tractor a few inches away from the backhoe.

NOTE - To facilitate this procedure, the backhoe can still be hydraulically moved, raised or lowered, to release the connection points of the carrying forces.

6. Gently lower the backhoe onto the blocking as shown in Fig 7. Leave the stabilizers outstretched and firmly in contact with the ground for added stability.

7. The hydraulic system can now be de-actuated.

CAUTION - Make sure tractor PTO is disengaged, and engine shut off before disconnecting pump or hydraulic lines.

- a. On PTO pump self-contained systems, the pump should be removed from the PTO shaft. The hydraulic system should always remain complete. No hoses or oil lines should be disconnected during correct removal and storage procedure.
- b. On systems that tap into the tractor for hydraulic power, these lines can be disconnected now.

IMPORTANT - Be sure to mark the lines to prevent mix up, during hook-up, when the hoe is again attached to the tractor.

Be sure to cap the ends of the lines to keep clean while in storage.

8. Now slowly drive the tractor forward and away from the backhoe. Be careful that all parts clear each other during separation.

9. Refer to the installation instructions for the attaching kit, this will help with the removal and reattaching.

10. For long term storage, coat exposed lift, swing, and stabilizer cylinder rods with grease.

11. Lubricate all grease fittings and oil stabilizer pivot pins, and complete handle linkage.

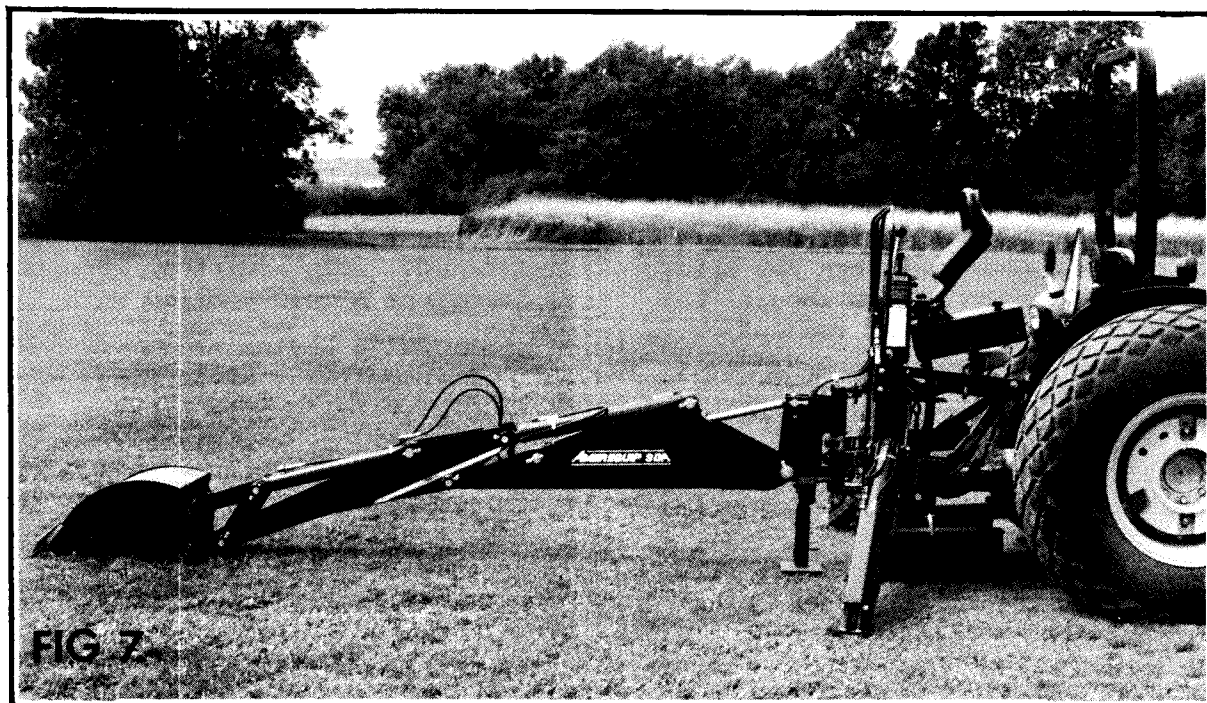

STABILIZER PADS - ACCESSORY ITEMS

The backhoe is supplied with bolt on stabilizer pads as standard equipment. They are suitable for most backhoe work and generally will be all that is ever required. However, accessory pads are available that pin to the standard pads to increase the versatility of the hoe. These items are shown below and are used in groups.

Group A - Basic flat plate that is pinned to the standard pad and has a limited amount of pivot action for leveling itself. It may be used as shown or have Groups B, B and C, or D added to it. It measures 9" x 10".

Group B - Four angles which may be bolted to Group A to form a soil engaging cleat in the form of a tee or a channel. The angles are 1-1/2" x 1-1/2" x 1/4" x 8-1/4" long.

Group C - A quantity of pierced belting strips and long bolts that can be added to Group B to form a rubber-fabric street pad.

Group D - A spike with two retaining nuts that can be attached to Group A in any quantity desired, up to six, per stabilizer. The spike will provide about 2" penetration.

STABILIZER PADS - PARTS LIST

Index	Description	Part No.
-------	-------------	----------

Group A:

	Turf Plate Kit (pair).....	W41
1	Pivot Shaft.....	601552
2	Turf Plate Weldment.....	851260
11	Cotter Pin.....	8602

Group B:

	Angle Kit (four Angles and four bolts).....	W42
3	Angle.....	851266
6	Bolt, 5/8 NF x 1-1/2.....	7130
8	Nut, 5/8 NF.....	7536
10	Lockwasher, 5/8.....	8111

Group C:

	Street Pad Kit (sufficient material for both stabilizers; includes four long bolts)....	W43
4	Street Pad, order.....	W43
7	Bolt, 5/8 NF x 6-1/2.....	7196
8	Nut, 5/8 NF.....	7536
10	Lockwasher, 5/8.....	8111

Group D:

	Spike Kit (eight spikes and sixteen nuts).....	W53
5	Spike, order.....	W53
8	Nut, 5/8 NF.....	7536
9	Jam Nut, 5/8 NF.....	7674

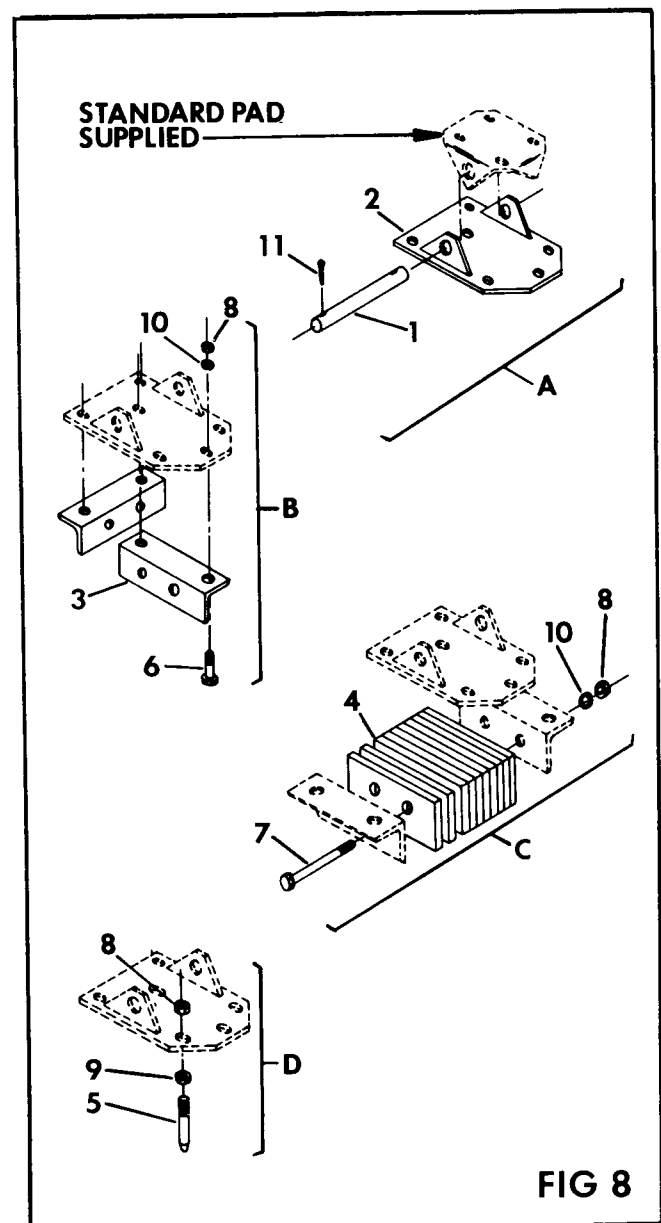

HYDRAULIC TROUBLE SHOOTING

The trouble shooting material presented in this section is offered as a guide to diagnosing probable causes and remedies for general operational problems. Match your problem with the typical problem examples given, and note the numbers given in the possible cause column. These numbers correspond with the possible cause and correction paragraphs that follow.

NOTE — When using the following chart if it is decided that overhaul of components or pressure adjustments are necessary, to correct malfunctioning, it is recommended that your dealer make these repairs. He is equipped to do this work.



WARNING: Escaping hydraulic/diesel fluid under pressure can penetrate the skin causing serious injury.

DO NOT use your hand to check for leaks. Use a piece of cardboard or paper to search for leaks.

Stop engine and relieve pressure before connecting or disconnecting lines.

Tighten all connections before starting engine or pressurizing lines.

If any fluid is injected onto the skin, obtain medical attention immediately or gangrene may result.

PROBLEM	POSSIBLE CAUSE
A. Machine fails to operate when started initially.....	1, 2, 5, 7, 16, 24
B. Machine loses power after operating satisfactorily initially.....	1, 8, 10, 14, 16, 24
C. Loss of power in lift or crowd cylinder, but other cylinders function properly.....	23, 25, 30
D. Loss of power in any one cylinder including lift and crowd.....	8, 9, 10, 11, 12, 13, 23, 25, 26
E. Loss of power or loss of cushioning action in swing cylinders, but other cylinders function properly.....	8, 9, 10, 11, 12, 13, 23, 24, 26, 27
F. Maximum swing action can not be obtained.....	12, 15
G. Slow operation of machine (lack of power) all cylinders.....	1, 4, 6, 14, 16, 24
H. Spongy or jerking action of cylinders and/or noisy operation.....	1, 3, 4, 5
I. Lift, crowd, or bucket cylinders drop under load when control spools are shifted from neutral.....	28, 30
J. Load drops or settles.....	8, 10, 13, 26, 28
K. Leaky cylinders.....	10, 11, 12, 13
L. Leaky valve.....	8, 16, 17, 29
M. Sticky valve spool.....	17, 20, 21, 22
N. Unable to push valve spool in.....	17, 18, 20, 21, 22
O. Spring centered spools do not return to neutral.....	17, 18, 19, 20, 21, 22

Hydraulic Trouble Shooting - continued

POSSIBLE CAUSE:

AND CORRECTION -

1. Low oil level in reservoir.....fill reservoir to proper level.
2. No oil supply to machine.....oil is not being diverted from the prime mover hydraulic system. Be sure that the proper controls are actuated on the prime mover.
3. Air in system.....bleed all circuits of air by operating machine at maximum oil flow and through full movements.
4. Oil viscosity too heavy, or oil is not at operating temperature.....use recommended hydraulic fluid. Run machine until oil reaches operating temperature.
5. Pump not running.....check pump drive to be sure it is engaged.
6. Insufficient pumping.....advance engine throttle.
7. Improper hose connection.....*IMPORTANT - Be sure inlet and return hoses are hooked up correctly. Improper hook-up will result in damage to the backhoe valve.*
8. Loose oil line connections, leaks in lines, or broken lines.....tighten all hose connections and replace any damaged O-rings at leaking O-ring fittings. Check and replace any damaged hoses and lines.
9. Restrictions in oil lines.....check and replace any damaged hoses and lines. Check for pinched hoses.
10. Oil is bypassing cylinder piston, scored piston, worn piston packing, or defective piston assembly.....replace or rebuild the cylinder; replace damaged parts.
11. Scored piston rods and worn rod guides in cylinder.....replace or rebuild the cylinder; replace damaged parts.
12. Bent piston rod in cylinder.....replace or rebuild the cylinder; replace damaged parts.
13. Worn or damaged rod seals on cylinder; external leaks.....repack cylinder. Rebuild cylinder, replacing damaged parts as necessary.
14. Diverter valve on prime mover leaking externally or bypassing oil internally through valve to reservoir.....diverter valve may need rebuilding or replacing.
15. Something jamming the swing linkage.....remove interference.
16. Excessive back pressure.....relieve condition. May be restriction from outlet to reservoir.

Hydraulic Trouble Shooting - continued

POSSIBLE CAUSE:

AND CORRECTION -

17. Paint on valve spool, sticking valve.....clean valve spool. Binding is usually spool, or scored valve spool. caused from an over tightened plug, mounting bolt, fitting in valve body, or tie rod bolt. If a plug or fitting in valve body is leaking do not over tighten in an effort to stop leak. This will distort body casting and cause spools to bind. Instead, the plug or fitting should be removed from valve body and be reconnected, using a new O-ring. Do not apply excessive pressure on mounting bolts. The rods should be torqued to 20 ft-lb. Never force spool, if binding occurs, see item 31 at the end.
18. Oil leakage past spool seal into.....remove cap, if it contains oil, replace spool cap. spool seal O-rings. Check O-ring retainer to see if it is flat. If it has been "belled" check for restriction from outlet to reservoir of valve which would cause excessive back pressure, see item 31 at the end and Fig 9.
19. Broken return springs.....replace springs, see item 31 at the end and Fig 9.
20. Bent spool.....replace with new spool section. See item 31 at the end and Fig 10, 11, and 12.
21. Foreign particles.....clean system and valve.
22. Misalignment of control handle.....check linkage for binding condition. linkage.
23. Spool not moved to full stroke.....check travel, should be 5/16 inch either way or a total of 5/8 inch. See item 31 at the end.
24. Relief valve setting in backhoe con-.....relief pressure will have to be checked trol valve too low or defective. and corrections made. Backhoe system pressure is 2200 PSI. Relief valve may need cleaning and overhauling, or entire cartridge must be replaced. See item 31 at the end and Fig 13.
25. Overload relief valve in the control.....clean relief carefully but do not dis- valve stuck open or malfunctioning. turb its pressure setting as it can not be field calibrated, or replace cartridge. See item 31 at the end and Fig 10 and 11.
26. Worn control valve.....replace the control valve.

Hydraulic Trouble Shooting - continued

POSSIBLE CAUSE:

AND CORRECTION -

27. A cross over relief in swing circuit.....clean reliefs carefully but do not disturb their pressure setting as they can not be field calibrated, or replace the entire cross over relief assembly.
28. Check poppet in the control valve.....clean check poppet(s) carefully, being sure that it moves freely with good spring action and seats properly or replace. See item 31 at the end and Fig 10, 11, and 12.
29. Damaged or worn spool seals.....replace spool end seals, see item 31 at the end and Fig 10, 11, and 12.
30. Check ball in anti-cavitation check.....clean anti-cavitation valve carefully, being sure that checks move freely and seat properly, or replace cartridge. See item 31 next, and Fig 10 and 11.
31. Problems involving the control valve proper.....

This valve is a precision device and is not intended for any extensive field adjustment or repair. Field replacement parts are limited to Seal Kits, Cartridges, Valve Sections, and Tie Rods. Replacement of these parts, the opening of check cavities and certain relief valve cavities to examine for trapped dirt, or the resetting of the main relief valve with the use of good pressure gauge, should be referred to qualified service personnel.

Dirt and shreds of packing material are the usual causes of valve malfunction. Be sure that the reservoir oil supply is kept clean and only factory supplied packings are used in cylinder repair. Everything must be clean and free of dirt during the oil line removal and replacement and during any cylinder work.

Pages 21 and 22, Valve Repair - Disassembly, explain the procedure to follow for valve repair. Pages 23 through 29 illustrate various portions of the valve and list the part numbers.

THE INCLUSION OF THIS INFORMATION AND ITS USE DOES NOT IMPLY THAT THE WARRANTY WILL REMAIN EFFECTIVE ON THE VALVE IF IT IS TAMPERED WITH DURING THE WARRANTY PERIOD.

VALVE REPAIR - DISASSEMBLY

Replace Center Section Assemblies:

NOTE - For the purpose of these instructions, we will consider the section containing the MAIN RELIEF VALVE as the left side of the valve.

1. Remove control valve from the backhoe.
2. Thoroughly clean the exterior of the valve before beginning disassembly procedures.
3. Since the valve will be assembled in the same order, each section should be marked numerically so that they can be reassembled in the same sequence.
4. Mount the valve vertically in a vise to facilitate disassembly and assembly.
5. Remove the three tie rod nuts from the right end section, using a thin-wall socket.
6. Valve sections can now be removed by sliding the sections along the tie rods.
7. Thoroughly clean the O-ring counter-bores and the ground surfaces of each section. Place O-ring seals; 10318 (exhaust) and 10317 (pressure) in proper counter-bores. For better sealing it is recommended that all O-rings, used in the counter-bores, are replaced with new parts.
8. Replace the sections on tie rods with the O-ring counter-bores facing the right end of the valve. Be careful replacing the sections so that the section O-rings are not moved from the counter-bores.
9. When all sections are assembled on the tie rods, tighten the tie rod nuts equally to 20 ft-lb torque, *NO MORE - NO LESS*, or spools may bind and stick.

Replacing Spool Seals:

NOTE - For the purpose of these instructions, we will consider the control handle side of the valve as the FRONT, and the opposite side the BACK.

1. Remove control valve from the backhoe.
2. Thoroughly clean the exterior of the valve before beginning disassembly procedures.
3. At the BACK of the valve remove all bonnet assembly parts which are connected to the spool, keep parts in the order of disassembly. See Fig 9 for the parts involved in the make-up of the bonnet assembly.

IMPORTANT - DO NOT remove the spool from the valve. The seals can be replaced externally. Prevent spool from turning or moving by inserting a screw driver through clevis slot, or by running a rod through the pin hole and using the rod as a handle. DO NOT hold the spool with a wrench. This will destroy the finish.

4. At the BACK of the valve, remove seal retainer, back-up washer, and spool O-ring seal, or retaining sleeve, bonnet O-ring seal, and spool U-cup seal.
5. Thoroughly clean counter-bores.
6. Install new seals:
 - A. Spring-Centered Bonnet Assembly Only:
Lightly oil new O-ring seal. Slide O-ring seal over valve spool and insert in seal counter-bore. Replace back-up washer and seal retainer.
 - B. Float Bonnet Assembly Only:
Replace retaining sleeve on valve spool. Lightly oil new U-cup seal. Slide U-cup seal over valve spool being careful to orient seal as shown in Fig 9. Install new O-ring seal in bonnet counter-bore.

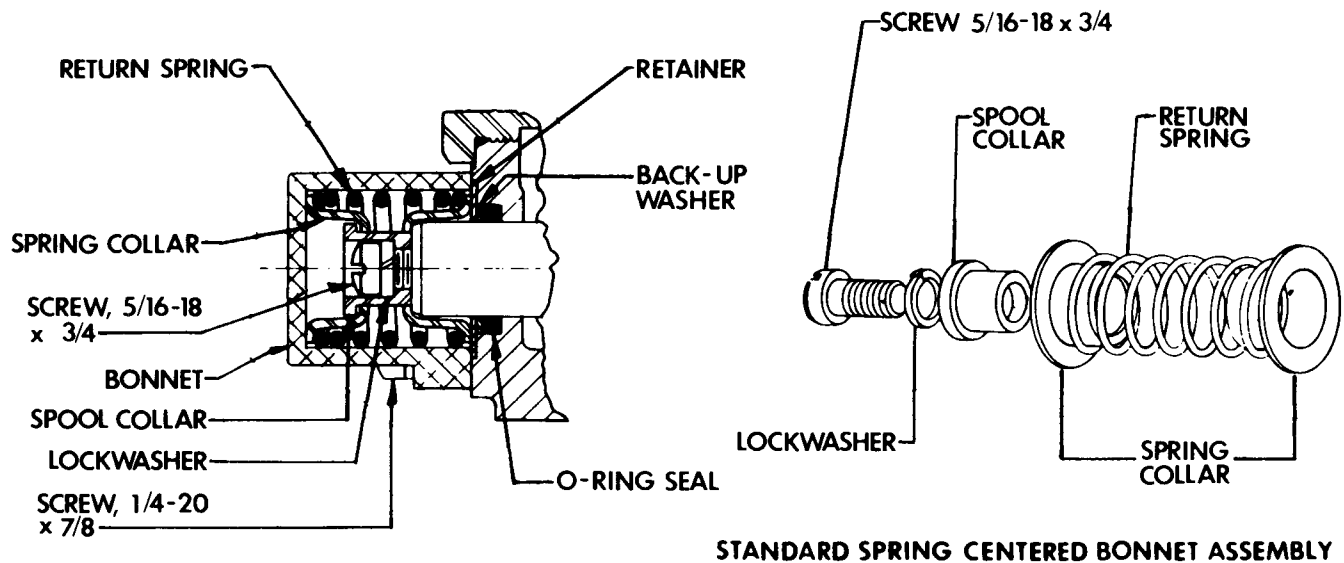

STANDARD SPRING CENTERED BONNET ASSEMBLY

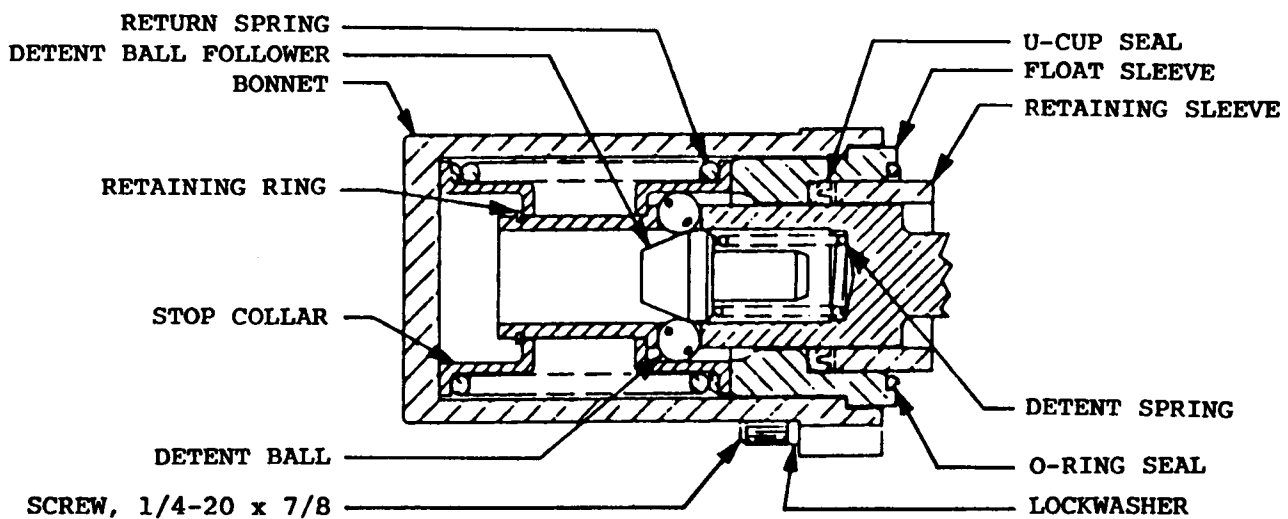

FIG 9

FLOAT BONNET ASSEMBLY

7. At the BACK of the valve replace bonnet assembly parts, reversing the order in which they were disassembled in step 3. Use 12 ft-lb torque to tighten assembly screw on spring centered bonnet assembly.

8. At the FRONT of the valve remove all parts connected to the spool (handle, linkage, etc.).

9. At the FRONT of the valve remove seal plate retainer, seal retainer, back-up washer, and spool O-ring seal.

10. Thoroughly clean counter-bore.

11. Lightly oil new O-ring seal. Slide O-ring seal over valve spool and insert in seal counter-bore. Replace back-up washer, seal retainer, and seal plate retainer.

12. Reattach all parts connected to the spool (handle, linkage, etc.).

CONTROL VALVE SECTION

TYPICAL SECTION FOR LIFT CIRCUIT

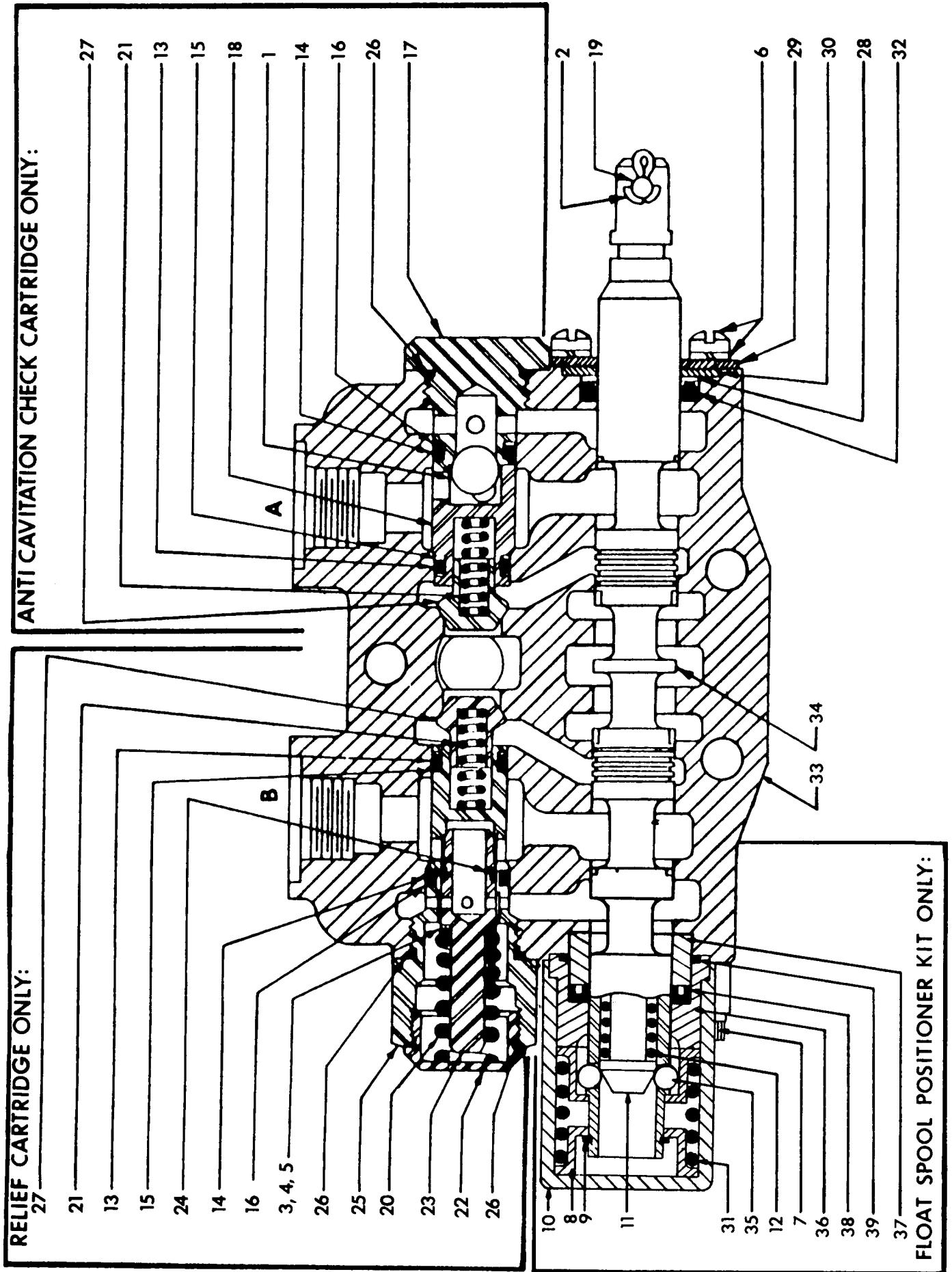

FIG 10

CONTROL VALVE SECTION - LIFT CIRCUIT

PARTS LIST - FIG 10

Index	Part No.	Description	Quantity Per Section
1	*	7/16" Steel Ball.....	1
2	8554	Handle Pin Cotter, 3/32 x 3/4.....	1
3,4,5	*	Shim, (.010", .020", .040" thick).....	as required
6	*	Machine Screw and Lockwasher.....	2
7	***	Bonnet Screw.....	2
8	***	Stop Collar.....	2
9	***	Retaining Ring.....	1
10	***	Bonnet.....	1
11	***	Detent Ball Follower.....	1
12	***	Detent spring.....	1
13	**	O-Ring Seal (Inner).....	2
14	**	O-Ring Seal (Outer).....	2
15	**	Back-Up Washer (Inner).....	4
16	**	Back-Up Washer (Outer).....	2
17	*	Anti-Cavitation Check Body.....	1
18	*	Check Ball Retainer.....	1
19	13436	Handle Clevis Pin, 1/4 dia. x 7/8.....	1
20	*	Spring (2201 - 3000 PSI Crack).....	1
21	*	Check Spring.....	2
22	*	Relief Cap.....	1
23	**	Relief Poppet.....	1
24	**	Piston Ring.....	1
25	*	Relief Body.....	1
26	**	O-Ring Seal.....	3
27	*	Steel Check.....	2
28	**	Back-Up Washer.....	2
29	*	Seal Plate Retainer.....	1
30	*	Seal Retainer.....	2
31	***	Centering Spring.....	1
32	**	Spool O-Ring Seal.....	2
33	*	Center Section Housing.....	1
34	*	Four-Way Spool.....	1
35	***	Detent Ball.....	4
36	***	Float Sleeve.....	1
37	***	Retaining Sleeve.....	1
38	**	U-Cup Seal.....	1
39	**	O-Ring Seal.....	1
	10522	Control Valve Section - Lift Circuit, consisting of above listed parts. <i>Note - One Orifice Plate (10193) must be added to "A" port to complete lift section.....</i>	1
	10516	Control Valve Section Seal Kit - Lift Circuit, consisting of: 32 (Qty 1), 13 (Qty 2), 14 (Qty 2), 28 (Qty 1), 38 (Qty 1), 39 (Qty 1), 15 (Qty 4), 16 (Qty 2), 26 (Qty 2), pressure section seal (Qty 2), and exhaust section seal (Qty 2).....	1
	10517	Spool Seal Kit; consisting of: 32 (Qty 1), 28 (Qty 1), 38 (Qty 1), and 39 (Qty 1).....	1
	10303	Relief Cartridge (2500 PSI), as shown.....	1
	10313	Relief Cartridge Seal Kit; consisting of: 13 (Qty 1), 14 (Qty 1), 15 (Qty 2), 16 (Qty 1), 26 (Qty 2)...	1
	10177	Poppet Seal Kit, consisting of: 23 (Qty 1) and 24 (Qty 1)...	1
	10304	Anti-Cavitation Check Cartridge, as shown.....	1
	10313	Anti-Cavitation Check Seal Kit, same as Relief Cartridge Seal Kit listed above.....	1
	10518	Float Spool Positioner Kit, as shown.....	1
	*	Not available as a separate repair part, order complete section or cartridge.	
	**	Not available as a separate repair part, order seal kit.	
	***	Not available as a separate repair part, order spool positioner kit.	

CONTROL VALVE SECTION

TYPICAL SECTION FOR CROWD CIRCUIT

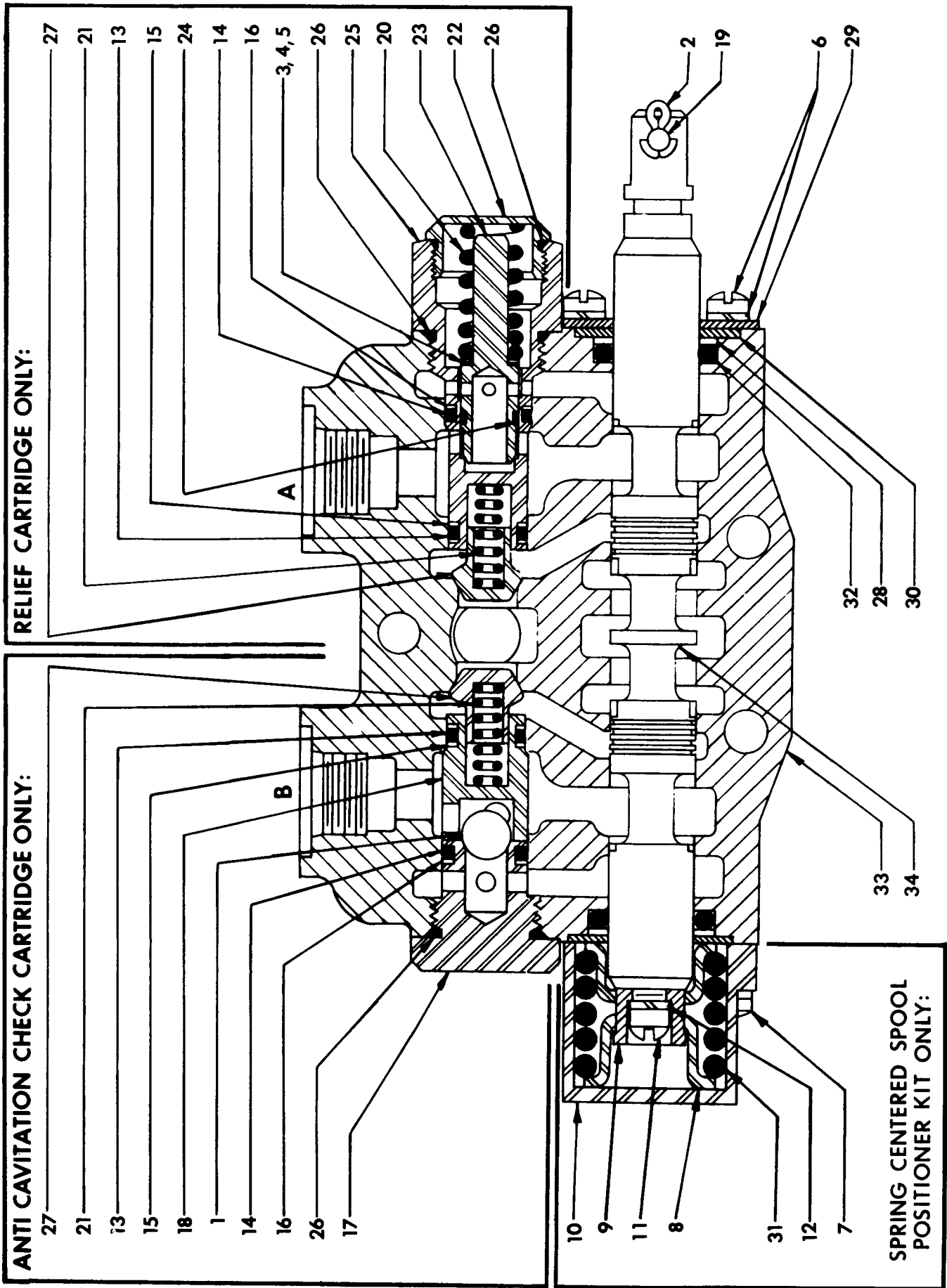

FIG 11

CONTROL VALVE SECTION - CROWD CIRCUIT

PARTS LIST - FIG 11

Index No.	Part No.	Description	Quantity Per Section
1	*	7/16" Steel Ball.....	1
2	8554	Handle Pin Cotter, 3/32 x 3/4.....	1
3	*	Shim, .040" Thick)	
4	*	Shim, .020" Thick).....	as required
5	*	Shim, .010" Thick)	
6	*	Machine Screw and Lockwasher.....	2
7	***	Bonnet Screw.....	2
8	***	Stop Collar.....	2
9	***	Spool Collar.....	1
10	***	Bonnet.....	1
11	***	Spool Assembly Screw.....	1
12	***	Spool Assembly Screw Lockwasher.....	1
13	**	O-Ring Seal (Inner).....	2
14	**	O-Ring Seal (Outer).....	2
15	**	Back-Up Washer (Inner).....	4
16	**	Back-Up Washer (Outer).....	2
17	*	Anti-Cavitation Check Body.....	1
18	*	Check Ball Retainer.....	1
19	13436	Handle Clevis Pin, 1/4 Dia x 7/8.....	1
20	*	Spring (2201 - 3000 PSI Crack).....	1
21	*	Check Spring.....	2
22	*	Relief Cap.....	1
23	**	Relief Poppet.....	1
24	**	Piston Ring.....	1
25	*	Relief Body.....	1
26	**	O-Ring Seal.....	3
27	*	Steel Check.....	2
28	**	Back-Up Washer.....	2
29	10321	Seal Plate Retainer.....	1
30	10322	Seal Retainer.....	2
31	***	Centering Spring.....	1
32	**	Spool O-Ring Seal.....	2
33	*	Center Section Housing.....	1
34	*	Four-Way Spool.....	1
	10155	Control Valve Section - Crowd Circuit, consisting of above listed parts.....	1
	10315	Control Valve Section Seal Kit - Crowd Circuit, consisting of: 32(quan-2), 13(quan-2), 14(quan-2), 15(quan-4), 16(quan-2), 26(quan-2), pressure section seal(quan-2), and exhaust section seal(quan-2).....	1
	10316	Spool Seal Kit; consisting of: 32(quan-2) and 28(quan-2).....	1
	10303	Relief Cartridge (2500 PSI), as shown.....	1
	10313	Relief Cartridge Seal Kit; consisting of: 13(quan-1), 14(quan-1), 15(quan-2), 16(quan-1), and 26(quan-2).....	1
	10177	Poppet Seal Kit, consisting of: 23(quan-1) and 24(quan-1).....	1
	10304	Anti-Cavitation Check Cartridge, as shown.....	1
	10313	Anti-Cavitation Check Seal Kit, same as Relief Cartridge Seal Kit listed above.....	1
	10107	Spring Centered Spool Positioner Kit, as shown.....	1

- * Not available as a separate repair part, order complete section or cartridge.
- ** Not available as a separate repair part, order seal kit.
- *** Not available as a separate repair part, order spool positioner kit.

CONTROL VALVE SECTION
 TYPICAL SECTION FOR ACTUATE (BUCKET), SWING, AND STABILIZER CIRCUITS

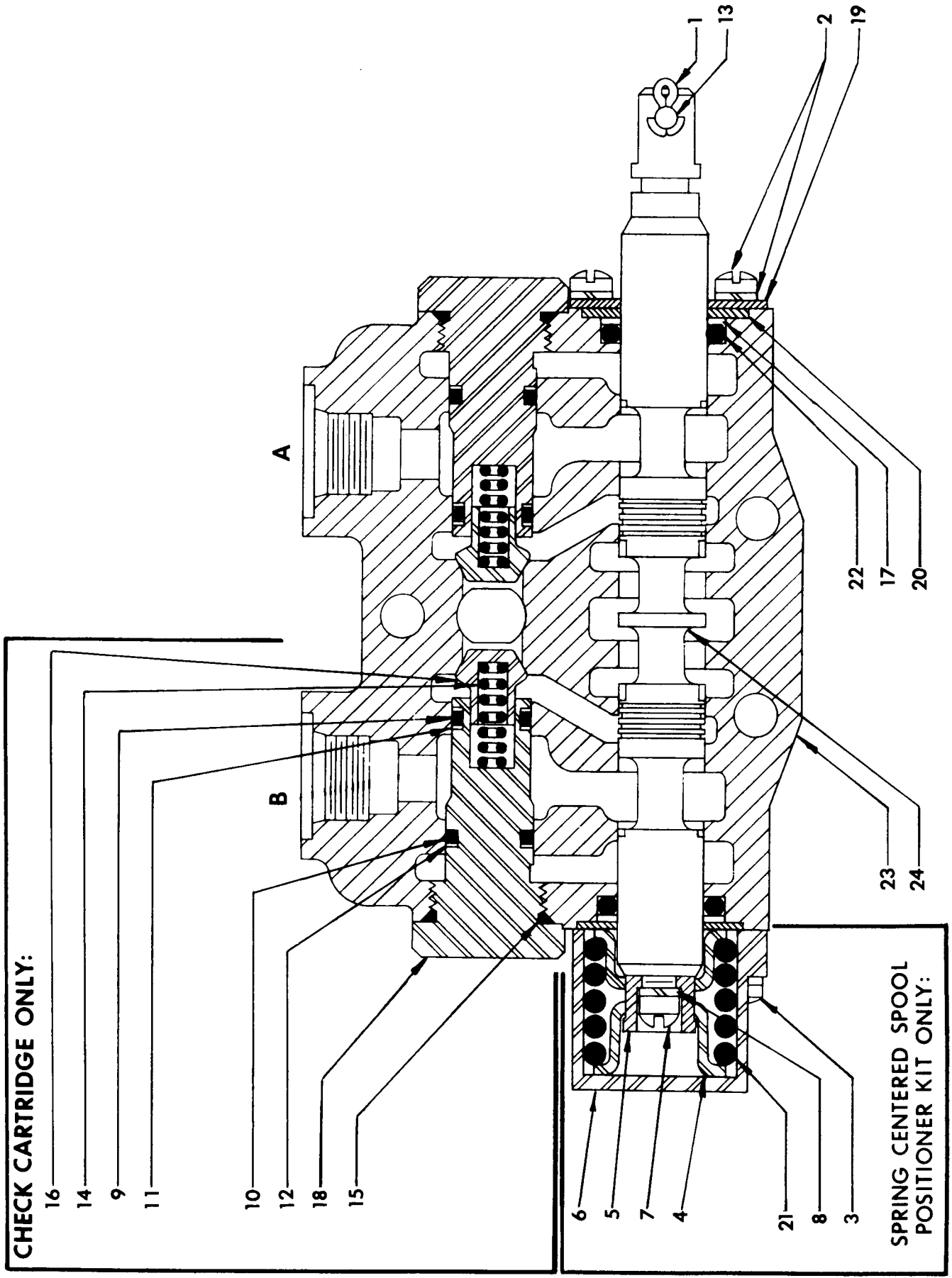

FIG 12

CONTROL VALVE SECTION - ACTUATE (BUCKET), SWING, AND STABILIZER CIRCUITS

PARTS LIST - FIG 12

Index No.	Part No.	Description	Quantity Per Section
1	8554	Handle Pin Cotter, 3/32 x 3/4.....	1
2	*	Machine Screw and Lockwasher.....	2
3	***	Bonnet Screw.....	2
4	***	Stop Collar.....	2
5	***	Spool Collar.....	1
6	***	Bonnet.....	1
7	***	Spool Assembly Screw.....	1
8	***	Spool Assembly Screw Lockwasher.....	1
9	**	Check Plug O-Ring Seal (Inner).....	2
10	**	Check Plug O-Ring Seal (Outer).....	2
11	**	Back-Up Washer (Inner).....	4
12	**	Back-Up Washer (Outer).....	2
13	13436	Handle Clevis Pin, 1/4 Dia x 7/8.....	1
14	*	Lift Check Spring.....	2
15	**	Lift Check Plug O-Ring Seal.....	2
16	*	Lift Check Poppet.....	2
17	**	Back-Up Washer.....	2
18	*	Lift Check Plug.....	2
19	10321	Seal Plate Retainer.....	1
20	10322	Seal Retainer.....	2
21	***	Centering Spring.....	1
22	**	Spool O-Ring Seal.....	2
23	*	Center Section Housing.....	1
24	*	Four-Way Spool.....	1
	10156	Control Valve Section - Actuate (Bucket), Swing, and Stabilizer Circuits, consisting of above listed parts.....	1
		<i>NOTE - Two Orifice Plates (10257) must be added to complete Swing Section.</i>	
	10315	Control Valve Section Seal Kit - Actuate (Bucket), Swing, and Stabilizer Circuits, consisting of: 22 (quan-2), 9 (quan-2), 10 (quan-2), 11 (quan-4), 12 (quan-2), 15 (quan-2), pressure section seal (quan-2), and exhaust section seal (quan-2).....	1
	10316	Spool Seal Kit; consisting of: 22 (quan-2) and 17 (quan-2).....	1
	10305	Check Cartridge, as shown.....	2
	10313	Check Cartridge Seal Kit; consisting of: 9 (quan-1), 10 (quan-1), 11 (quan-2), 12 (quan-1), and 15 (quan-2).....	2
	10107	Spring Centered Spool Positioner Kit, as shown.....	1

- * Not available as a separate repair part, order complete section or cartridge.
- ** Not available as a separate repair part, order seal kit.
- *** Not available as a separate repair part, order spool positioner kit.

MAIN SYSTEM RELIEF VALVE (2200 PSI)

LOCATION: LEFT HAND VALVE COVER

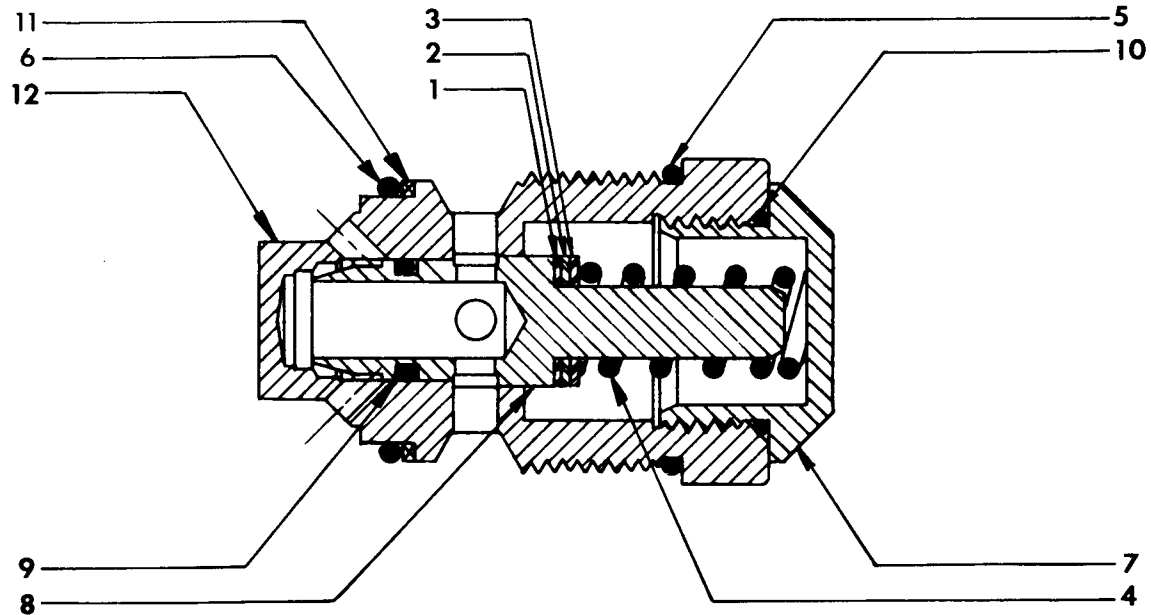

FIG 13

MAIN SYSTEM RELIEF VALVE

PARTS LIST - FIG 13

Index No.	Part No.	Description	Required
1	*	Shim, .040" Thick)	
2	*	Shim, .020" Thick).....	as required
3	*	Shim, .010" Thick)	
4	*	Spring (2201 - 3000 PSI Crack).....	1
5	**	O-Ring Seal.....	1
6	**	O-Ring Seal.....	1
7	*	Relief Cap.....	1
8	**	Relief Poppet.....	1
9	**	Piston Ring.....	1
10	**	O-Ring Seal.....	1
11	**	Back-Up Washer.....	1
12	*	Body.....	1
	23020	Main System Relief Valve, consisting of above listed parts.....	1
	10172	Seal and Service Kit; consisting of: 5(quan-1), 6(quan-1), 8(quan-1), 9(quan-1), 10(quan-1), and 11(quan-2).....	1

* Not available as a separate repair part, order complete Main System Relief Valve.

** Not available as a separate repair part, order Seal and Service Kit.

ADDITIONAL REPAIR PARTS (NOT SHOWN)

Part No.	Description	Required
23021	Left Hand End Cover with Main Relief Valve.....	1
10160	Tie Rod Kit (Six-Spool) contains three Studs and three Stud Nuts.....	1
10176	Valve Seal Kit, containing all O-Rings and Back-Up Rings for a Six-Spool Valve.....	1
23019	Six-Spool Valve.....	1
10308	Right Hand End Cover.....	1
10317	Section Seal (Pressure).....	2
10318	Section Seal (Exhaust).....	2

VALVE MOUNT, CONTROLS, AND SEAT

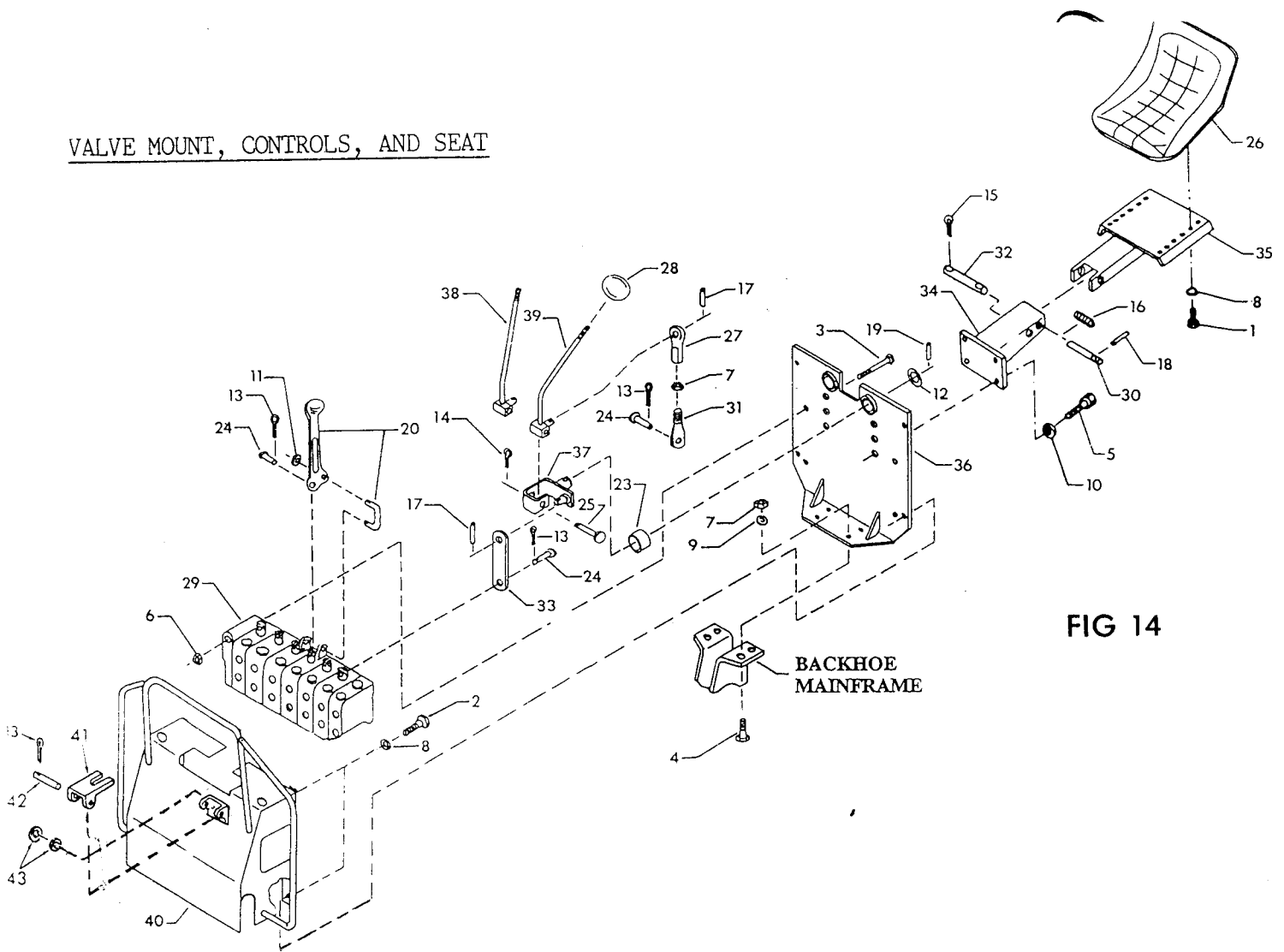

FIG 14

PARTS LIST - FIG. 14 SERIAL NUMBER 2128 AND LATER

Index	Description	Part No.
1	Bolt, 5/16 NC x 3/4	6787
2	Bolt, 5/16 NF x 1	6795
3	Bolt, 5/16 NC x 2-3/4	6819
4	Bolt, 3/8 NF x 1-1/4 Gr. 8	6860
5	Bolt, 1/2 NF x 1	7012
6	Locknut, 5/16 NC	7433
7	Nut, 3/8 NF Gr. 5	7461
8	Lockwasher, 5/16	8071
9	Lockwasher, 3/8	8079
10	Lockwasher, 1/2	8101
11	Flat Washer, 3/16	8141
12	Machine Bushing, 1-1/2 OD x 1 ID x 18GA	8283
13	Cotter Pin, 3/32 x 3/4	8554
14	Cotter Pin, 5/32 x 1-1/4	8574
15	Cotter Pin, 3/16 x 1-1/4	8582
16	Spring	8711
17	Roll Pin, 5/32 x 3/4	8953
18	Roll Pin, 3/16 x 2	8978

Index	Description	Part No.
19	Roll Pin, 3/8 x 1-3/4	9018
20	Stabilizer Handle Complete	10144
23	Bronze Bushing, 1-1/4 OD x 1 ID x 1	11993
24	Clevis Pin, 1/4 Dia x 7/8	13436
25	Clevis Pin, 1/2 Dia x 2-1/4	13454
26	Seat	13919
27	Ball Joint, 3/8 NF Female	14029
28	Round Knob, 1/2 NC	14058
29	Control Valve	23019
30	Slide Pin	851988
31	Handle Link	856226
32	Pin, 5/8 Dia x 5-5/8	856256
33	Link	856451
34	Seat Bracket Assembly	860135
35	Seat Plate Weldment	856475
36	Valve Plate, with Bushings	857955
37	Linkage Pivot Weldment	857960
38	R.H. Control Handle	857965
39	L.H. Control Handle	857970
40	Valve Shroud	857655
41	Latch Plate	859336
42	Pin	859338
43	Flat Washer, 5/16 SAE	8152

NOTE: Lock bolt with permanent
thread lock (Loctite #271)

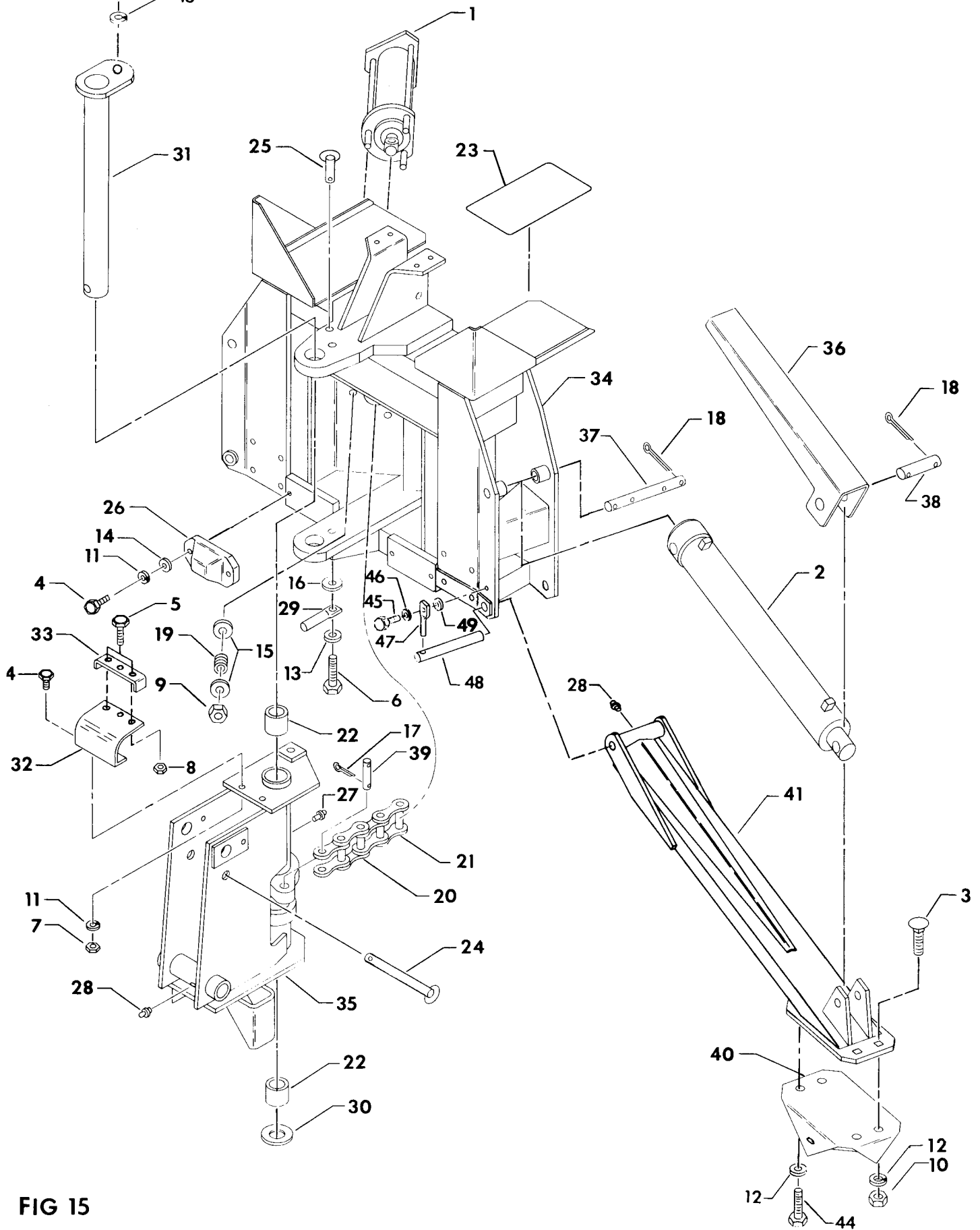

FIG 15

MAINFRAME, SWING FRAME, AND STABILIZERS

PARTS LIST - FIG 15

<u>Index</u>	<u>Description</u>	<u>Part No.</u>	<u>SERIAL NUMBER</u>	
			<u>2128 AND LATER</u>	
1	Hydraulic Cylinder - Swing.....	098		
2	Hydraulic Cylinder - Stabilizer.....	122		
3	Carriage Bolt, 1/2 NC x 1-1/4.....	6664		
4	Bolt, 5/16 NF x 1".....	6795		
5	Bolt, 5/16 NF x 1-1/4.....	6799		
6	Bolt, 1/2 NF x 1".....	7012		
7	Nut, 5/16 NF.....	7436		
8	Locknut, 5/16 NF.....	7437		
9	Locknut, 7/16 NF.....	7487		
10	Nut, 1/2 NC.....	7501		
11	Lockwasher, 5/16.....	8071		
12	Lockwasher, 1/2.....	8101		
13	Lockwasher, 1/2 shakeproof.....	8103		
14	Flat Washer, 5/16.....	8151		
15	Flat Washer, 7/16.....	8163		
16	Flat Washer, 1/2 SAE.....	8173		
17	Cotter Pin, 3/16 x 1-1/4 Hardened.....	8582		
18	Cotter Pin, 1/4 x 1-1/2.....	8602		
19	Spring, 1/2 ID x 1-3/4.....	8711		
20	Three-Link Section, extra heavy 160, less 17, 21, 39 ...	857139		
21	Connector Link, extra heavy 160.....	11433		
22	Bronze Bushing.....	11989		
23	Foot Pad Surfacing.....	12906		
			<u>Index</u>	<u>Description</u>
				<u>Part No.</u>
			24	Quick Release Pin, 3/4 Dia. x 7-1/4.....
				13501
			25	Quick Release Pin, 5/8 Dia. x 2".....
				13496
			26	Bumper.....
				13681
			27	Grease Fitting, 1/8 NPT.....
				14500
			28	Grease Fitting, 1/4 self tapping.....
				14505
			29	Pin Retainer, large.....
				851123
			30	Thrust Washer.....
				851136
			31	Swing Shaft.....
				857800
			32	Hose Bracket.....
				856236
			33	Hose Strap.....
				856237
			34	Mainframe Weldment.....
				857975
			35	Swing Frame with bushings..
				857810
			36	Stabilizer Shield.....
				858575
			37	Stabilizer Pin.....
				857131
			38	Stabilizer Cylinder Pin....
				857132
			39	Chain Pin.....
				857133
			40	Stabilizer Pad.....
				857922
			41	Stabilizer Weldment.....
				857875
			42	Bolt, 5/8 NF x 1".....
				7112
			43	Lockwasher, 5/8 Shakeproof...
				8114
			44	Bolt, 1/2 NC x 1".....
				7008
			45	Bolt, 3/8 NF x 1".....
				6851
			46	Lockwasher, 3/8 Shakeproof...
				8081
			47	Pin Retainer.....
				13474
			48	Stabilizer Pin.....
				858079
			49	Spacer.....
				858081

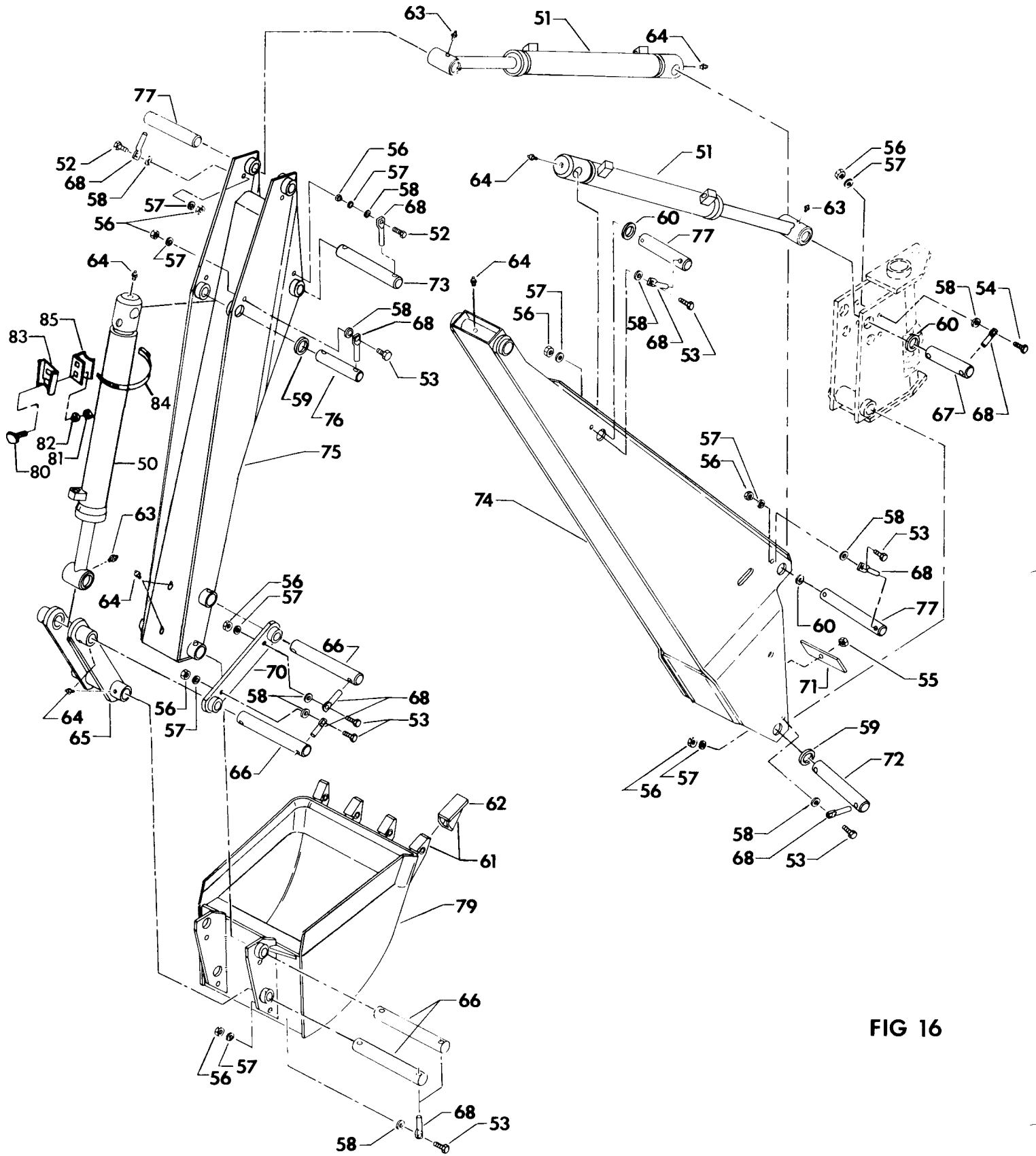





FIG 16

BOOM, DIPPERSTICK, AND BUCKET

SERIAL NUMBER 2128 AND LATER

PARTS LIST - FIG 16

Index	Description	Part No.	Index	Description	Part No.
50	Hydraulic Cylinder - Bucket...	078	68	Pin Retainer.....	13474
51	Hydraulic Cylinder - Boom/Dipperstick.....	097	70	Guide Link.....	857315
52	Bolt, 3/8 NF x 1".....	6851	71	Hose Strap.....	857124
53	Bolt, 3/8 NF x 1-1/4.....	6859	72	Boom Pivot Pin.....	857126
54	Bolt, 3/8 NF x 1-1/2.....	6864	73	Dipperstick Pivot Pin.....	857128
55	Locknut, 3/8 NC.....	7458	74	Boom Weldment.....	857840
56	Nut, 3/8 NF Gr. 5.....	7461	75	Dipperstick Weldment.....	857855
57	Lockwasher, 3/8.....	8079	76	Bucket Cylinder Pin.....	857301
58	Flat Washer, 3/8 SAE.....	8158	77	Cylinder Pin.....	857302
59	Machine Bushing, 2-1/4 OD x 1-1/2 ID x 16 GA.....	8232	79	Bucket Complete - 12".....	W462
60	Machine Bushing, 1-7/8 OD x 1-1/4 ID x 18 GA.....	8290	79	Bucket Complete - 18".....	W463
61	Tooth and Shank Assembly....	13613	79	Bucket Complete - 24".....	W464
62	Tooth Point.....	13617	79	Bucket Complete - 36".....	W460
63	Grease Fitting, 1/8 NPT.....	14500	79	Bucket Complete - 40".....	W461
64	Grease Fitting, 1/4 self tapping.....	14505	80	Carriage Bolt, 5/16 NC x 3/4.....	6574
65	Bucket Link Weldment.....	851090	81	Nut, 5/16 NC.....	7431
66	Bucket Linkage Pin.....	851116	82	Lockwasher, 5/16.....	8071
67	Pivot Shaft.....	851118	83	SMV Socket.....	13683
			84	Hose Clamp.....	14140
			85	SMV Socket Mount.....	857921

TORQUE VALUES			
Common bolts and nuts.		Tightening Torque \pm 20%	
SIZE	GRADE 2 	GRADE 5 	GRADE 8 
1/4-20 NC	70 in lb	115 in lb	165 in lb
1/4-28 NF	85 in lb	140 in lb	200 in lb
5/16-18 NC	150 in lb	250 in lb	350 in lb
5/16-24 NF	165 in lb	270 in lb	30 ft lb
3/8-16 NC	260 in lb	35 ft lb	50 ft lb
3/8-24 NF	300 in lb	40 ft lb	60 ft lb
7/16-14 NC	35 ft lb	55 ft lb	80 ft lb
7/16-20 NF	45 ft lb	75 ft lb	105 ft lb
1/2-13 NC	50 ft lb	80 ft lb	115 ft lb
1/2-20 NF	70 ft lb	105 ft lb	165 ft lb
9/16-12 NC	75 ft lb	125 ft lb	175 ft lb
9/16-18 NF	100 ft lb	165 ft lb	230 ft lb
5/8-11 NC	110 ft lb	180 ft lb	260 ft lb
5/8-18 NF	140 ft lb	230 ft lb	330 ft lb
3/4-10 NC	150 ft lb	245 ft lb	350 ft lb
3/4-16 NF	200 ft lb	325 ft lb	470 ft lb

NOTE - See tractor instruction manual or your tractor dealer for tightening of metric bolts.

Index	Description	Part No.	Index	Description	Part No.
150	Bolt, 5/16 NC x 2-1/2.....	6813	157	Hydraulic Hose, 1/4 ID x 3/8 NPT x 70".....	17110
151	Nut, 5/16 NC.....	7431	158	Hydraulic Hose, 1/4 ID x 3/8 NPT x 45".....	17045
152	Street Elbow, 3/8 NPT x 90°.....	11179	159	Hydraulic Hose, 1/4 ID x 3/8 NPT x 80".....	17135
153	Lockwasher, 5/16.....	8071	160	Hydraulic Hose, 1/4 ID x 3/8 NPT x 115".....	17215
154	Cross-Over Relief, 1500 psi.....	10190			
155	Hydraulic Hose, 1/4 ID x 3/8 NPT x 20".....	17015			
156	Hydraulic Hose, 1/4 ID x 3/8 NPT x 13".....	17005			

FIG 17

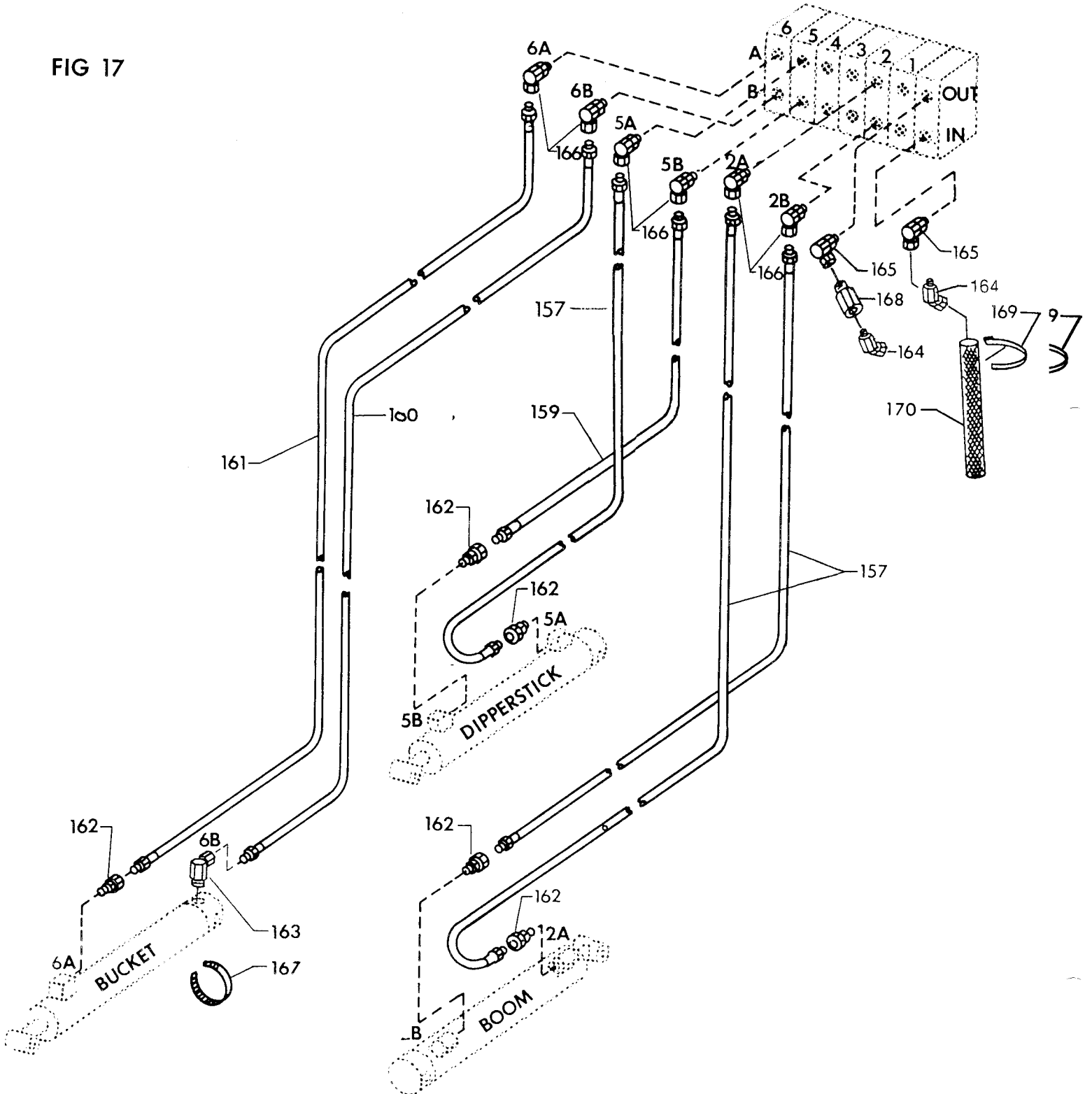

Index	Description	Part No.	Index	Description	Part No.
161	Hydraulic Hose, 1/4 ID x 3/8 NPT x 135"	17235	166	Adapter Union, 3/4-16 M x 3/8 NPT F x 90°	11143
162	Adapter Union, 3/8 NPT M x 3/8 NPT F	11109	167	Plastic Tie	14128
163	Adapter Union, 3/8 NPT M x 3/8 NPT F x 90°	11127	168	Check Valve	10166
164	Adapter Union, 1/2 NPT M x 1/2 NPT F x 45°	11131	169	Plastic Tie	14121
165	Adapter Union, 7/8 -14 M x 1/2 NPT F x 90°	11142	170	Hose Sleeve, 1-9/16 ID x 18"	14127
			171	Plastic Tie	14133
			172	Adapter Union, 3/8 NPT M x 3/8 NPT F x 45°	11135
			173	Breather Hose.....	857924

FIG 18

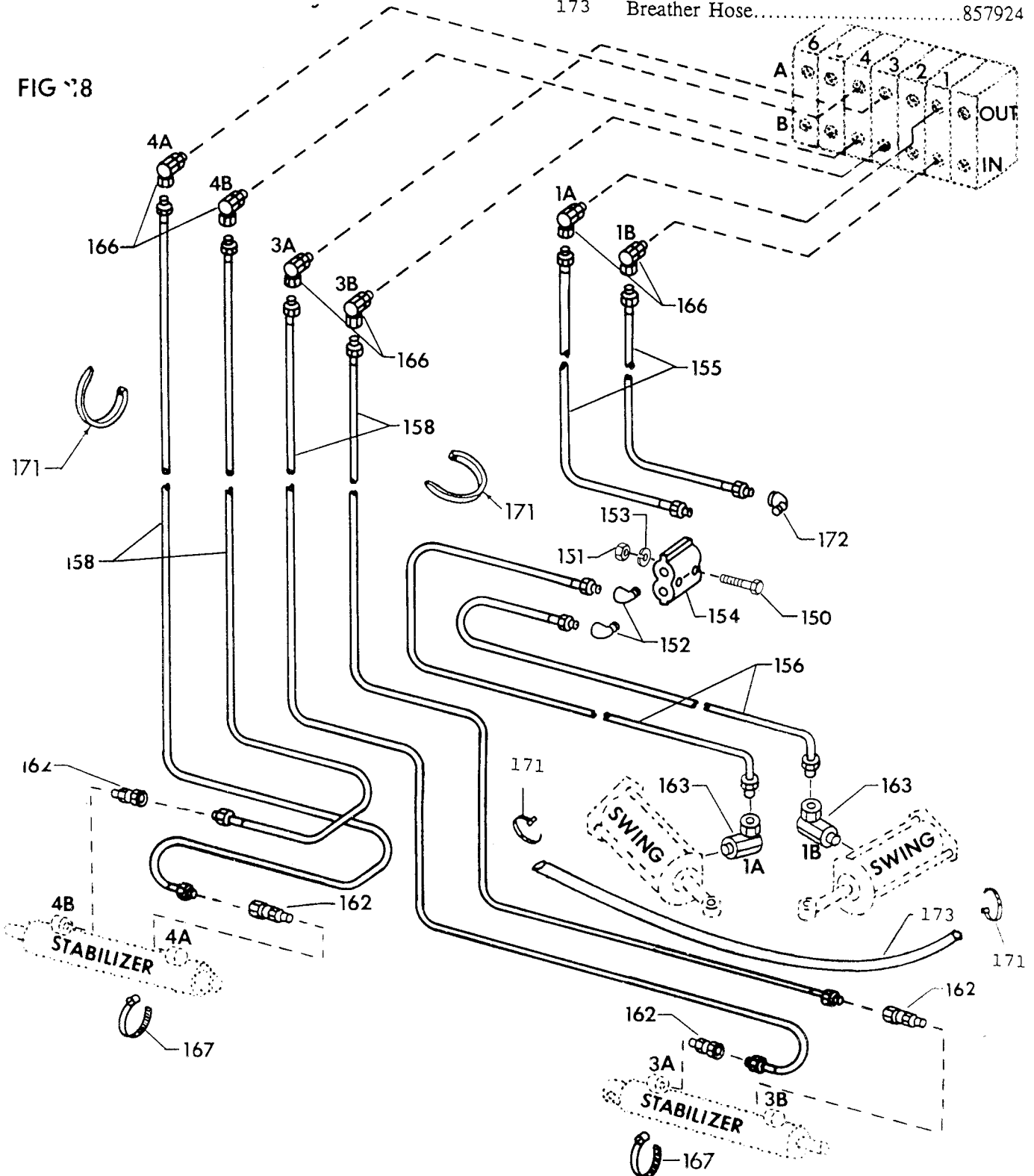

097 Cylinder
Lift and Crowd

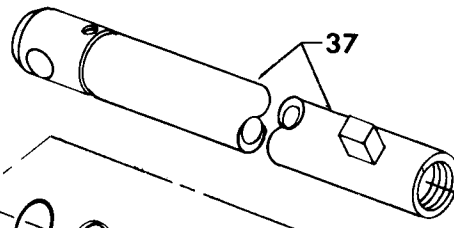

Torque: 260 lb.-ft.

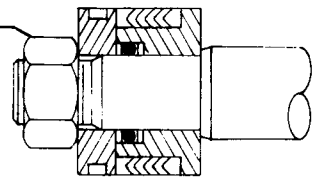

Proper Piston Assembly

078 Cylinder
Bucket

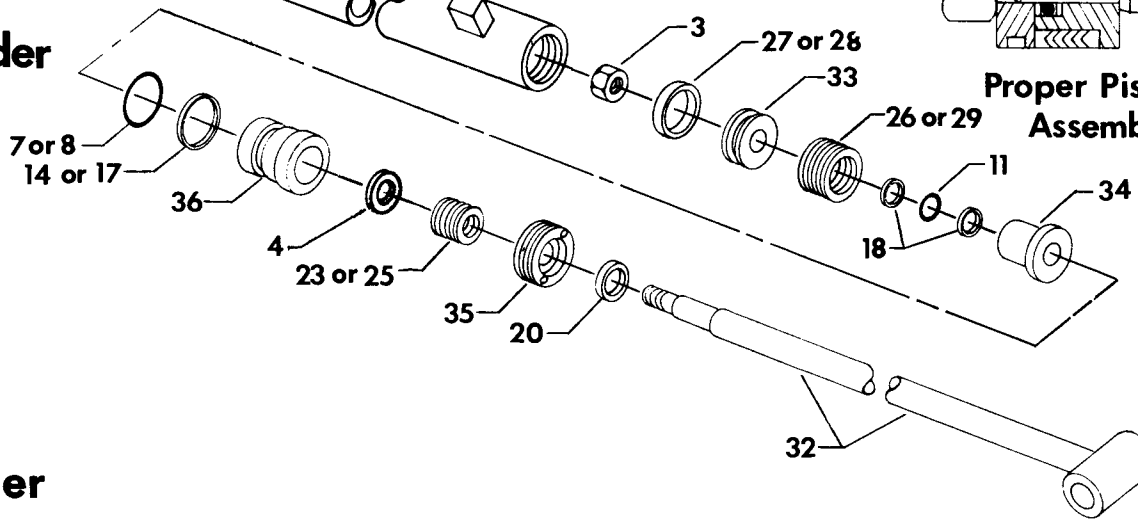

122 Cylinder
Stabilizer

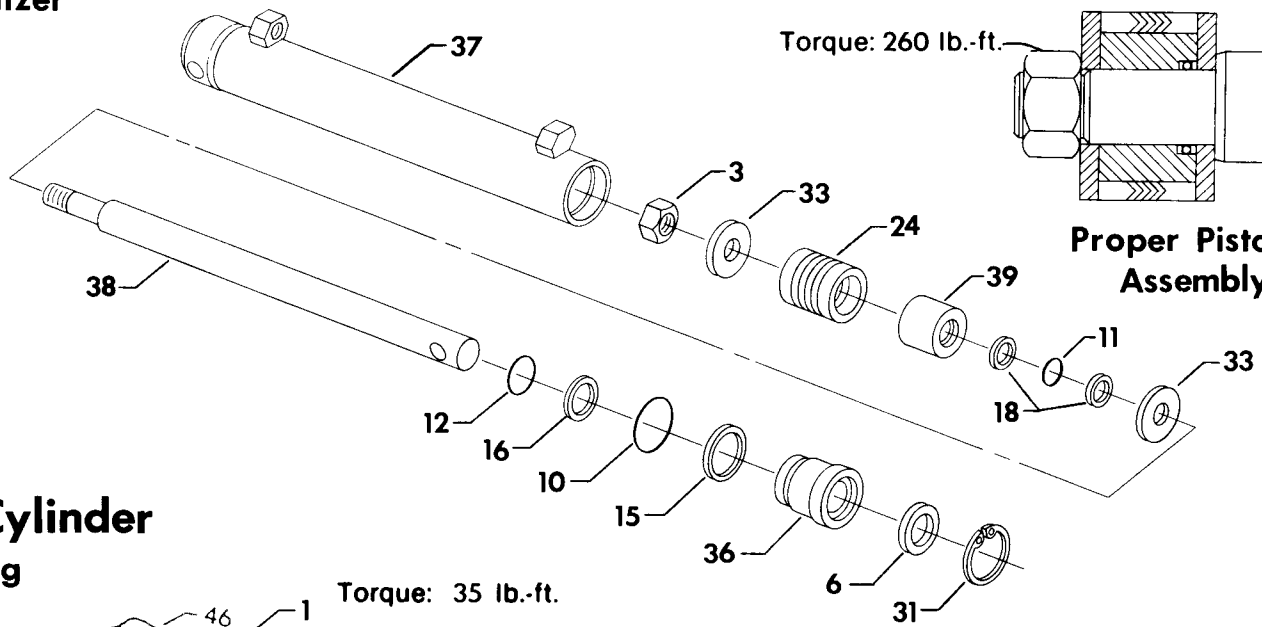

Torque: 260 lb.-ft.

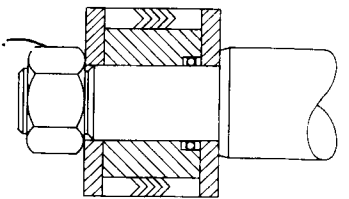

Proper Piston Assembly

098 Cylinder
Swing

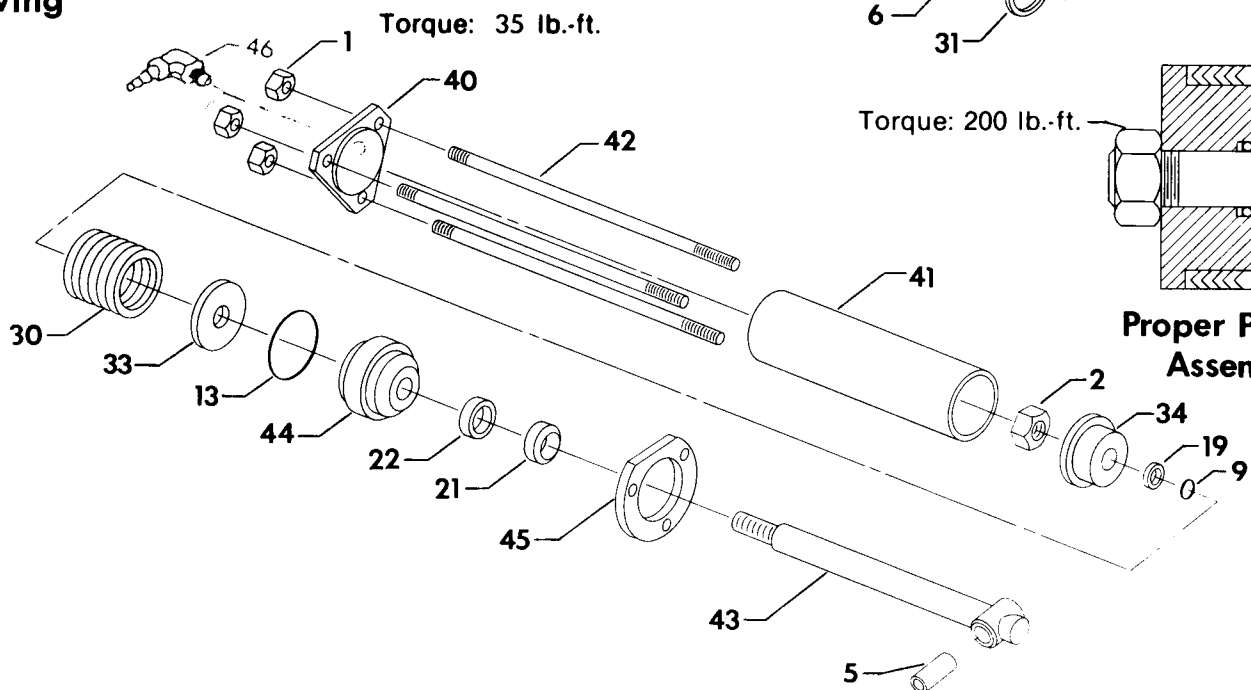

Torque: 35 lb.-ft.

Torque: 200 lb.-ft.

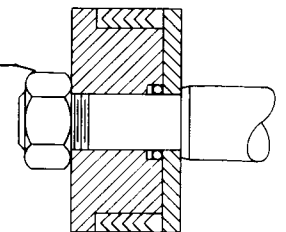

Proper Piston Assembly

HYDRAULIC CYLINDERS - PARTS LIST

Index	Description	078:	097:	098:	122:
1	Lock Nut, 7/16 NF.....			7487	
2	Lock Nut, 3/4 NF Nyloc.....			7574	
3	Lock Nut, 7/8 NF Nyloc.....	7609	7609		7609
4	Washer, 1-3/4 OD x 1-1/4 ID Wavy Spring.....		*		
5	Chain Pin Bushing.....			11427	
6	Oil Seal, 1-7/8 OD x 1-1/2 ID.....				*
7	O-Ring, 2-1/4 OD x 2-1/16 ID.....	*			
8	O-Ring, 2-9/16 OD x 2-3/8 ID.....		*		
9	O-Ring, 1" OD x 3/4 ID.....			*	
10	O-Ring, 2-1/2 OD x 2-5/16 ID.....				*
11	O-Ring, 1-1/4 OD x 1" ID.....	*	*		*
12	O-Ring, 1-3/4 OD x 1-1/2 ID.....				*
13	O-Ring, 3" OD x 2-3/4 ID.....			*	
14	Back-Up Ring, 2-1/4 OD x 2-1/16 ID.....	*			
15	Back-Up Ring, 2-1/2 OD x 2-5/16 ID.....				*
16	Back-Up Ring, 1-3/4 OD x 1-1/2 ID.....				*
17	Back-Up Ring, 2-1/2 OD x 2-3/8 ID.....		*		
18	Back-Up Ring, 1-1/4 OD x 1" ID.....	*	*		*
19	Back-Up Ring, 1" OD x 3/4 ID.....			*	
20	Oil Seal, 1-5/8 OD x 1-1/4 ID.....	*	*		
21	Oil Seal, 1-3/8 OD x 1" ID.....			*	
22	Rod Seal, 1-3/8 OD x 1" ID.....			*	
23	Packing Assembly, 1-3/4 OD x 1-1/4 ID.....	*			
24	Packing Assembly, 2-1/2 OD x 2" ID.....				*
25	Packing Assembly, 1-3/4 OD x 1-1/4 ID.....		*		
26	Packing Assembly, 2-1/4 OD x 1-3/4 ID.....	*			
27	Wear Ring, 2-1/4 OD x 2" ID.....	*			
28	Wear Ring, 2-1/2 OD x 2-1/4 ID.....		*		
29	Packing Assembly, 2-1/2 OD x 2" ID.....		*		
30	Packing Assembly, 3" OD x 2-1/2 ID.....			*	
31	Retaining Ring, Internal.....				*
32	Piston Rod Weldment.....	904910	905435		
33	Washer.....	904916	905179	906229	905126
34	Piston with O-Ring and Back-Ups.....	904920	905175	906225	
35	Gland Cap.....	904918	905178		
36	Gland with O-Rings and Back-Ups.....	904925	905220		905420
37	Cylinder Tube Weldment.....	904935	905395		905410
38	Piston Rod.....				905421
39	Piston Spacer with O-Ring and Back-Ups.....				905425
40	End Plate.....			906239	
41	Cylinder Tube.....			906216	
42	Bolt.....			906217	
43	Piston Rod Assembly with Bushing.....			906220	
44	End Cap.....			906226	
45	Nut Plate.....			906228	
46	Hose Barb.....			11290	
	For Complete Cylinder, order.....	078	097	098	122
	Seal Repair Kit (includes all Packings, Wear Rings, O-Rings, Back-Up Rings, and seals for one cylinder).....	904930	905045	906230	905430

* Not available as a separate repair part - order seal repair kit.

SPECIFICATIONS

General Data:

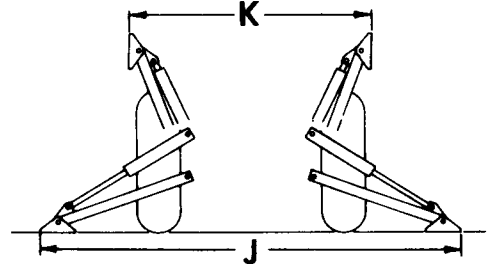
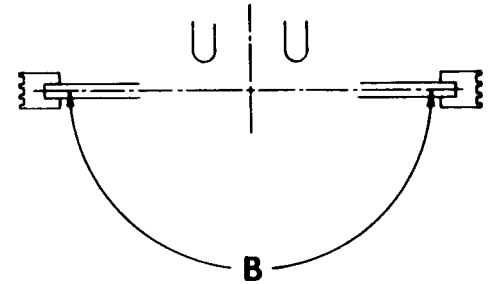
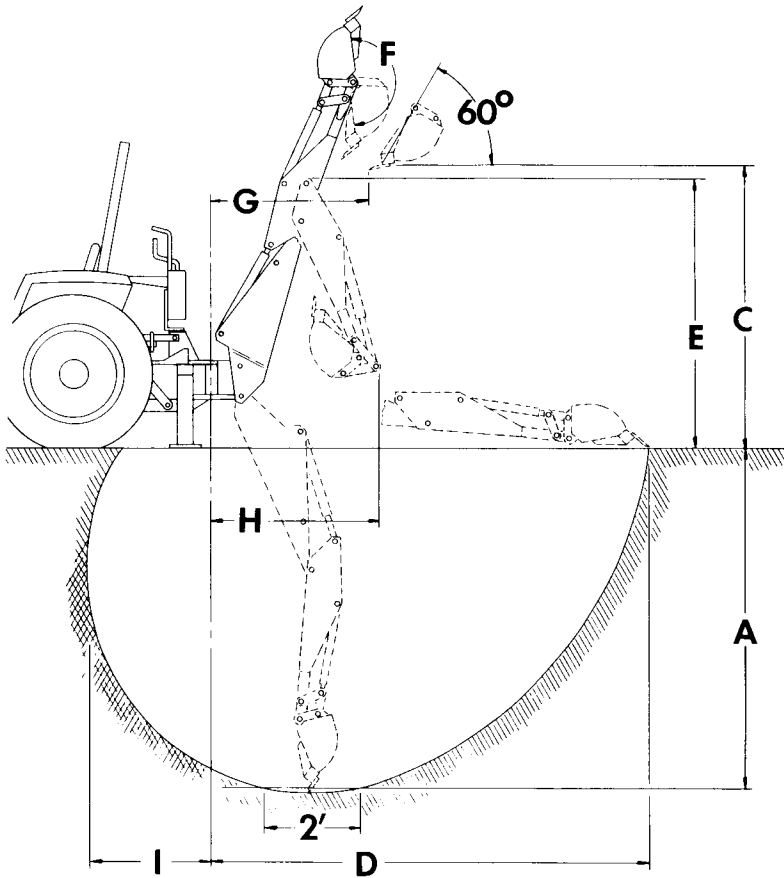

- A. Digging Depth.....8' 6"
(two foot flat bottom)
- B. Swing Arc.....180°
- C. Loading Height.....6' 10"
(bucket at 60°)
- D. Reach from Center Line of
Swing Pivot.....11' 1"
- E. Transport Height (maximum).....6' 9"
- F. Bucket Rotation.....180°
- G. Loading Reach.....3' 7"
(bucket at 60°)
- H. Transport Overhang.....4' 0"
- I. Undercut.....2' 10"

- J. Stabilizer Spread,
down position.....8' 3"

- K. Stabilizer Spread,
up position.....4' 6"

Bucket Cylinder
Digging Force.....3450 lbs.

Dipperstick Cylinder
Digging Force.....2250 lbs.

Shipping Weight
(less bucket).....1030 lbs.

Hydraulic Volume
Requirements.....5 to 7 GPM

Hydraulic Pressure
Requirements.....2200 psi

SPECIFICATIONS

Bucket Data:

BUCKET	WIDTH	SAE STRUCK CAPACITY	HEAPED CAPACITY	SHIPPING WEIGHT
W462	12 in. (305 MM)	1.14 cu.ft. (.032 M ³)	1.74 cu.ft. (.049 M ³)	82 lbs. (37 kg)
W463	18 in. (455 MM)	1.75 cu.ft. (.046 M ³)	2.68 cu.ft. (.076 M ³)	101 lbs. (46 kg)
W464	24 in. (610 MM)	2.42 cu.ft. (.068 M ³)	3.71 cu.ft. (.105 M ³)	117 lbs. (53 kg)
W460	36 in. (915 MM)	3.77 cu.ft. (.107 M ³)	5.76 cu.ft. (.163 M ³)	154 lbs. (70 kg)
W461	40 in. (1015 MM)	4.22 cu.ft. (.119 M ³)	6.41 cu.ft. (.181 M ³)	170 lbs. (77 kg)

Cylinder Data:

CYLINDER	PISTON DIA.	STROKE	RETRACTED LENGTH	EXTENDED LENGTH	ROD DIA.	PIVOT PIN DIA.	TYPE OF ACTION
097 - BOOM/DIPPER	2-1/2 (64 MM)	21 (533 MM)	31 (787 MM)	52 (1321 MM)	1-1/4 (32 MM)	1-1/4 (32 MM)	DA
078 - BUCKET	2-1/4 (57 MM)	18 (457 MM)	26 (660 MM)	44 (1178 MM)	1-1/4 (32 MM)	1-1/2 Base 1-1/4 Rod (32 MM)	DA
122 - STABILIZER	2-1/2 (64 MM)	15 (381 MM)	22-1/16 (560 MM)	37-1/16 (941 MM)	1-1/2 (38 MM)	7/8 (22 MM)	DA
098 - SWING	3** (76 MM)	8-15/16 (227 MM)	DNA***	DNA***	1 (25 MM)	DNA***	SA

** Effective area is 3" diameter less 1" diameter for rod, or 6.28 sq. in.
(pull type cylinder).

*** Spherical socket mounted cylinder.

PURCHASE AND SERVICE RECORD _____



**be careful.....
avoid accidents**